



Ball and Socket Joints

Ball and socket joints to DIN 71802 available in zinc plated steel and stainless steel.
Right and left hand threads available.

Sizes M5 up to M16.



Pages 65 - 68

Ball and Socket Joints - with sealing caps

Ball and socket joints to DIN 71802 available in zinc plated steel and stainless steel.
Right and left hand threads available.

Sizes M5 up to M16.



Pages 69 - 72

Ball and Socket Joints - with sealing caps and spanner flats

Ball and socket joints to DIN 71802 available in zinc plated steel and stainless steel.
Right and left hand threads available. Spanner flats on housing to aid installation.

Sizes M5 up to M16.



Pages 73 - 76

Axial Ball and Socket Joints

In-line ball and socket joints to DIN 71802 available in zinc plated steel and stainless steel.

Sizes M5 up to M14 x 1,5.



Pages 77 - 80

Threaded Ball Studs

Threaded ball studs to DIN 71803 form C available in zinc plated steel.

Sizes M5 up to M14.



Pages 87



R3500

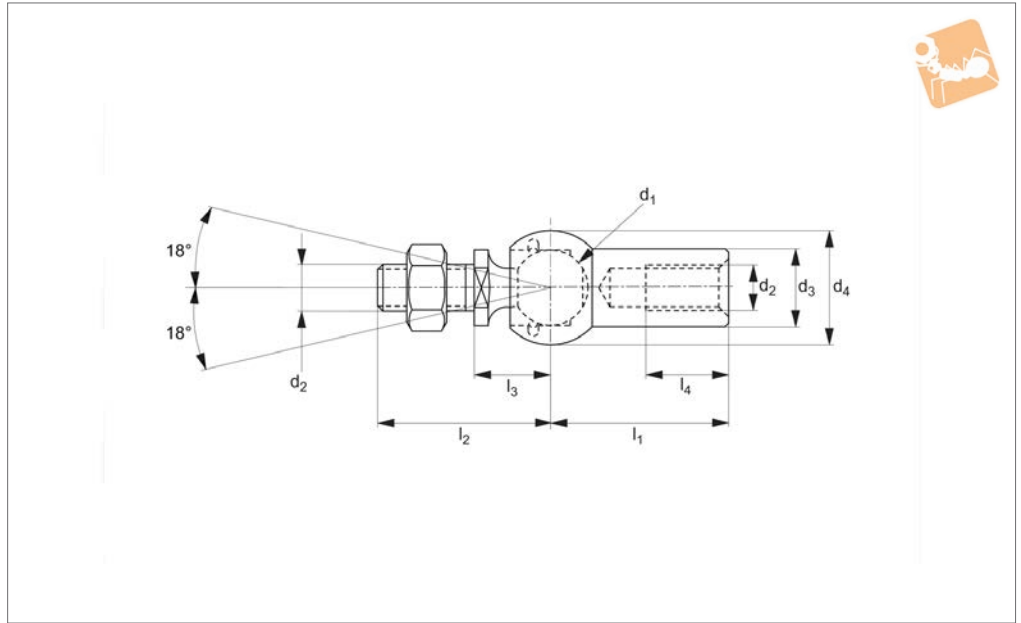

Material

Steel, silver zinc plated, ball stud: minimum tensile strength $R_m=600N/mm^2$.
Housing: minimum tensile strength $R_m=500N/mm^2$.

Technical Notes

Similar to DIN 71802, *M14x1,5 is a fine pitch thread.

Tips

Standard thread is right hand, (for left hand thread see R3501).
For stainless steel version see R3506.

Order No.	Thread hand	d_1 tol. h9	d_2	l_1	d_3 ± 0.5	d_4 ± 0.5	l_2	l_3	l_4	Extraction force N	Weight g
R3500.R005	Right	8	M 5	22	8	12.8	19.2	9	10.2	30	15.2
R3500.R006	Right	10	M 6	25	10	14.8	23.5	11	11.5	40	25.2
R3500.R008	Right	13	M 8	30	13	19.3	29.5	13	14.0	60	53.1
R3500.R010	Right	16	M10	35	16	24.0	36.0	16	15.5	80	103.8
R3500.R014	Right	19	M14x1,5*	45	22	30.0	48.0	20	21.5	100	220.9



Axial Ball and Socket Joints

left hand thread

Ball & Socket Joints

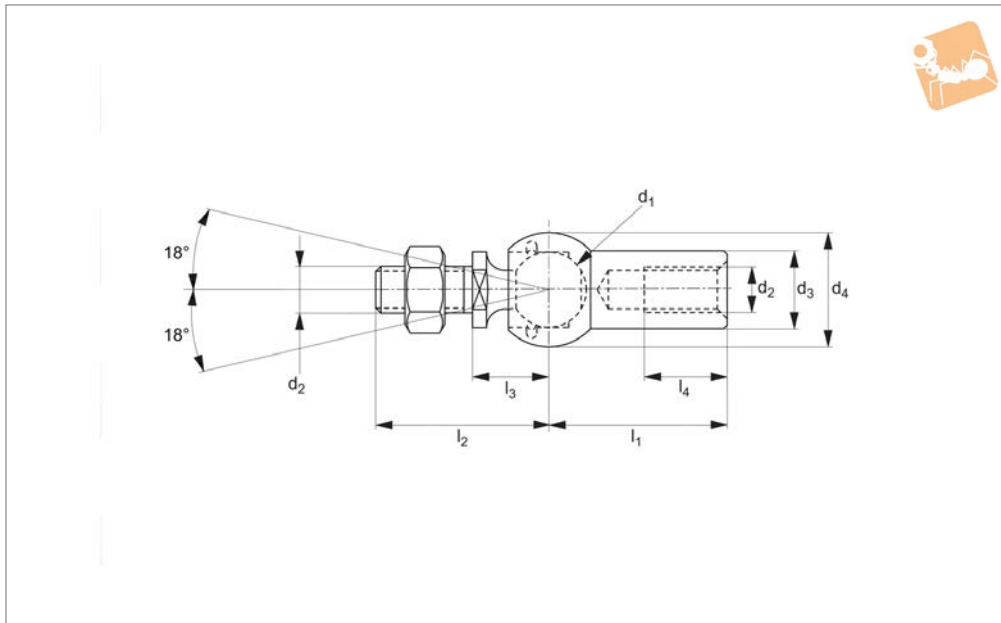

R3501

BALL & SOCKET JOINTS

Material

Steel, silver zinc plated, ball stud:
minimum tensile strength $R_m=600N/mm^2$.
Housing: minimum tensile strength

$R_m=500N/mm^2$.

Technical Notes

Similar to DIN 71802, *M14x1,5 is a fine

pitch thread.

Tips

For stainless steel version see R3507.

Order No.	Thread hand	d_1 tol. h9	d_2	l_1	d_3 ± 0.5	d_4 ± 0.5	l_2	l_3	l_4	Extraction force N	Weight g
R3501.L005	Left	8	M5	22	8	12.8	19.2	9	10.2	30	15.2
R3501.L006	Left	10	M6	25	10	14.8	23.5	11	11.5	40	25.2
R3501.L008	Left	13	M8	30	13	19.3	29.5	13	14.0	60	53.1
R3501.L010	Left	16	M10	35	16	24.0	36.0	16	15.5	80	103.8
R3501.L014	Left	19	M14x1,5*	45	22	30.0	48.0	20	21.5	100	220.9



R3506

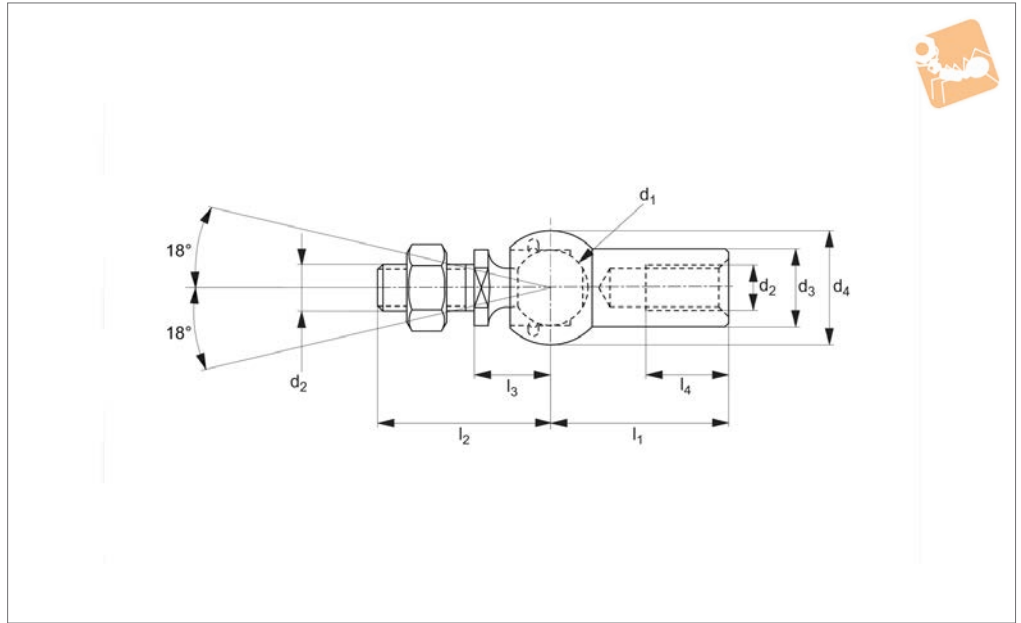

Material

Stainless steel (AISI 303).

pitch thread.

Technical Notes

Similar to DIN 71802, *M14x1,5 is a fine

Tips

Standard thread is right hand, (for left hand thread see R3507).

Order No.	Thread hand	d ₁ tol. h9	d ₂	l ₁	d ₃ ±0.5	d ₄ ±0.5	l ₂	l ₃	l ₄	Extraction force N	Weight g
R3506.R005	Right	8	M5	22	8	12.8	19.2	9	10.2	30	15.2
R3506.R006	Right	10	M6	25	10	14.8	23.5	11	11.5	40	25.2
R3506.R008	Right	13	M8	30	13	19.3	29.5	13	14.0	60	53.1
R3506.R010	Right	16	M10	35	16	24.0	36.0	16	15.5	80	103.8
R3506.R014	Right	19	M14x1,5*	45	22	30.0	48.0	20	21.5	100	220.9



Stainless Axial Ball and Socket Joints

left hand thread

Ball & Socket Joints

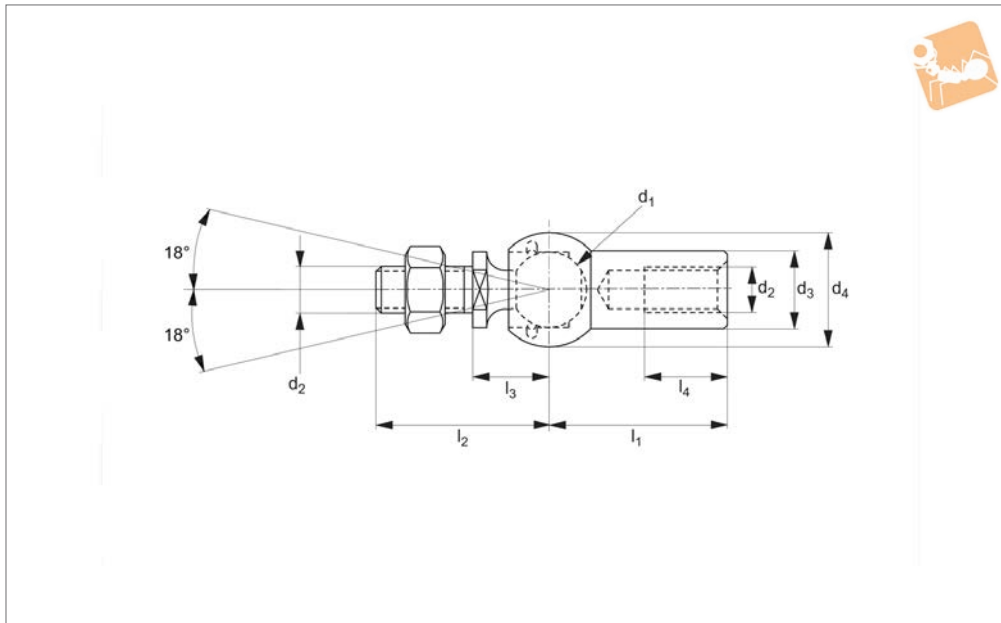

R3507

BALL & SOCKET JOINTS

Material

Stainless steel (AISI 303).

Technical Notes

Similar to DIN 71802, *M14x1,5 is a fine pitch thread.

Order No.	Thread hand	d ₁ tol. h9	d ₂	l ₁	d ₃ ±0.5	d ₄ ±0.5	l ₂	l ₃	l ₄	Extraction force N	Weight g
R3507.L005	Left	8	M5	22	8	12.8	19.2	9	10.2	30	15.2
R3507.L006	Left	10	M6	25	10	14.8	23.5	11	11.5	40	25.2
R3507.L008	Left	13	M8	30	13	19.3	29.5	13	14.0	60	53.1
R3507.L010	Left	16	M10	35	16	24.0	36.0	16	15.5	80	103.8
R3507.L014	Left	19	M14x1,5*	45	22	30.0	48.0	20	21.5	100	220.9



R3524

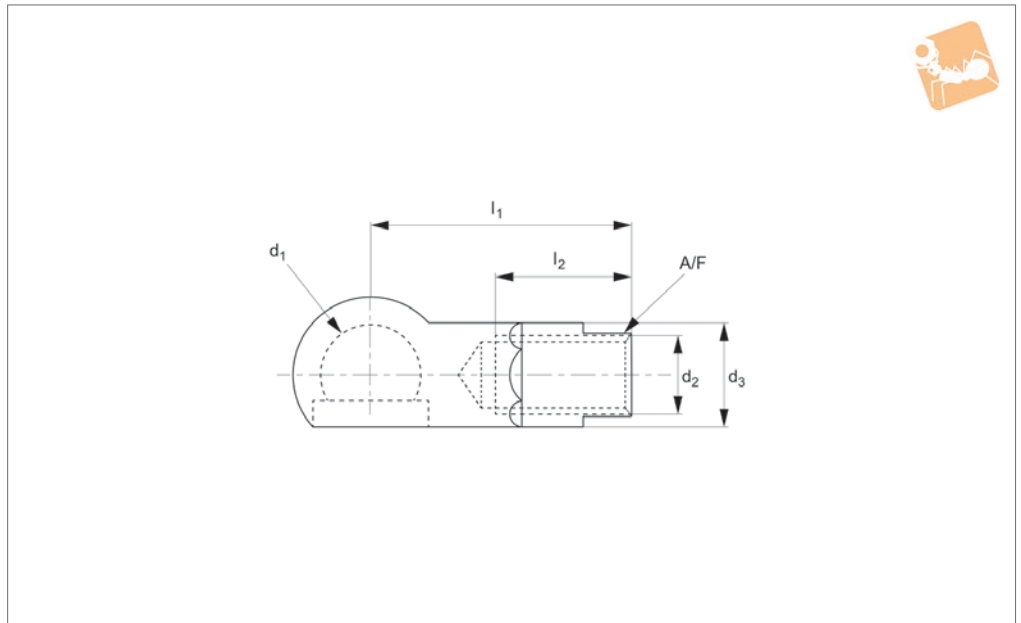

Material

Low carbon steel, silver zinc plated.

Technical Notes

To DIN 71802.

Tips

Standard thread is right hand thread.

Important Notes

These ball joints are used in light linkage applications where it is desired to have the ability to be able to remove the ball stud.

The ball joint is supplied WITHOUT the ball stud and retaining clip.

Order No.	Thread hand	d ₁	d ₂	l ₁	l ₂	d ₃	A/F
R3524.R005	Right	8	M 5	22	10.2	8	7
R3524.R006	Right	10	M 6	25	11.5	10	9
R3524.R008	Right	13	M 8	30	14.0	13	11
R3524.R010	Right	16	M10	35	15.5	16	13
R3524.R012	Right	16	M12	35	15.5	16	13

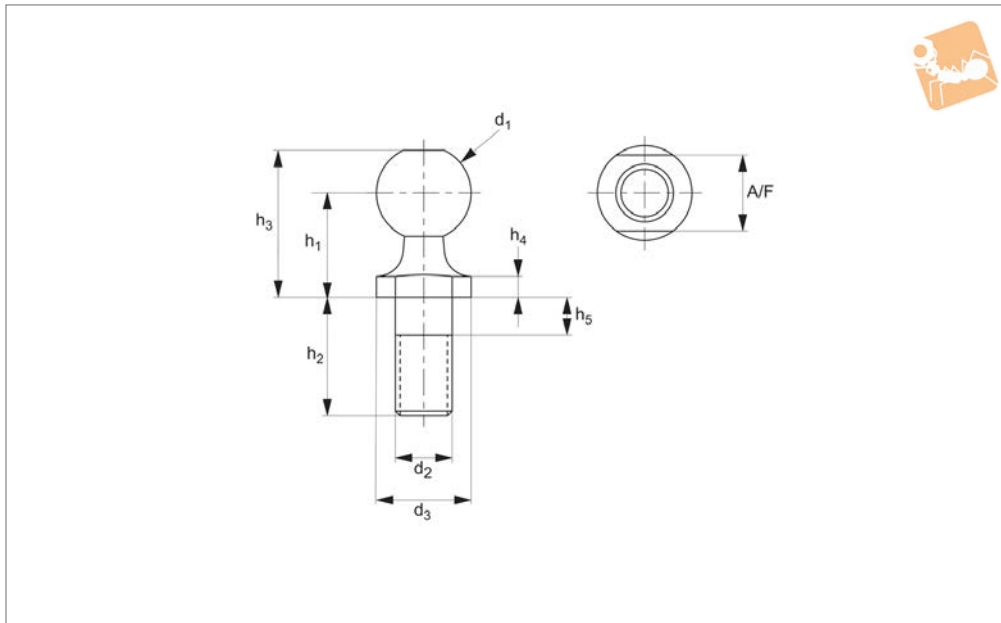

R3526

BALL & SOCKET JOINTS

Material

Low carbon steel (1018), silver zinc plated.

Technical Notes

To DIN 71803 Form C, *M14x1.5 is a fine pitch thread.

Order No.	d_1 tol. h9	d_2	d_3 +0.0 -0.2	h_1 ± 0.3	h_2 ± 0.3	h_3 ± 0.3	h_4 +0.4 -0.0	h_5 max.	A/F	Weight g
R3526.005	8.0	M5	8.0	9.0	10.2	12.5	2.0	4.0	7.0	4.5
R3526.006	10.0	M6	10.0	11.0	12.5	15.5	2.2	4.0	8.0	8.5
R3526.008	13.0	M8	13.0	13.0	16.5	18.5	2.4	5.3	11.0	17.7
R3526.010	16.0	M10	16.0	16.0	20.0	23.0	2.7	7.3	13.0	35.0
R3526.012	16.0	M12	16.0	16.0	20.0	23.0	2.7	7.3	13.0	35.0
R3526.014	19.0	M14 x 1.5*	19.0	20.0	28.0	28.5	3.0	10.8	16.0	71.2
R3526.015	19.0	M14	19.0	20.0	28.0	28.5	3.0	10.8	16.0	71.2
R3526.016	19.0	M16	19.0	20.0	28.0	28.5	3.0	10.8	16.0	71.2



R3527

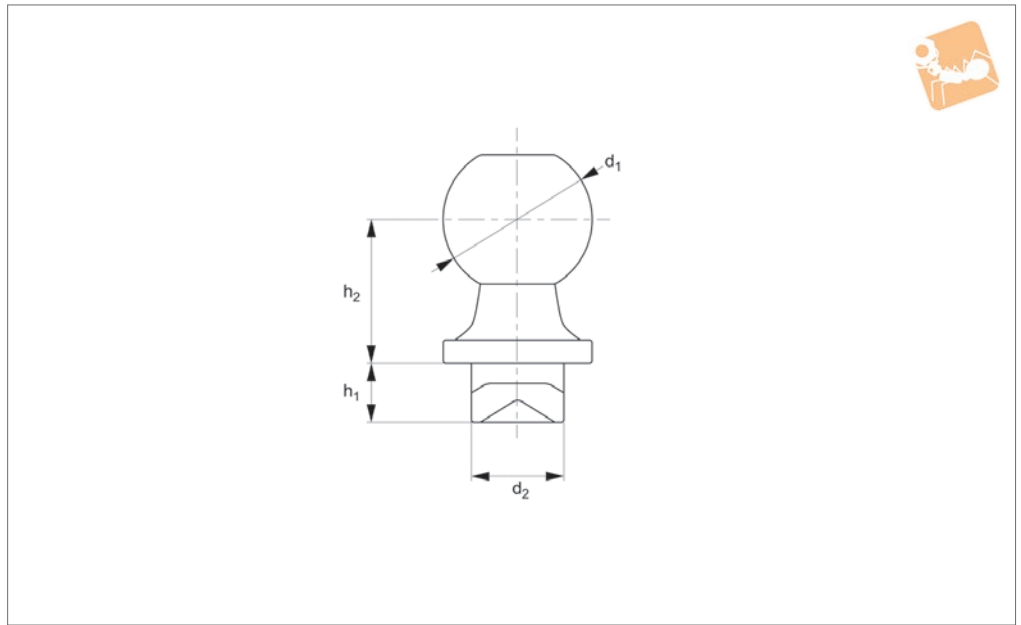

Material

Low carbon steel (1018), silver zinc plated.

Technical Notes

To DIN 71803 Form B

*M14x1.5 is a fine pitch thread.

Order No.	d_1	d_2 tol. h_{11}	h_1 ± 0.2	h_2 ± 0.3
R3527.080-040	8.0	5.0	4.0	9.0
R3527.080-075	8.0	5.0	7.5	9.0
R3527.100-045	10.0	6.0	4.5	11.0
R3527.100-080	10.0	6.0	8.0	11.0
R3527.130-050	13.0	8.0	5.0	13.0
R3527.130-100	13.0	8.0	10.0	13.0
R3527.160-060	16.0	10.0	6.0	16.0
R3527.160-130	16.0	10.0	13.0	16.0

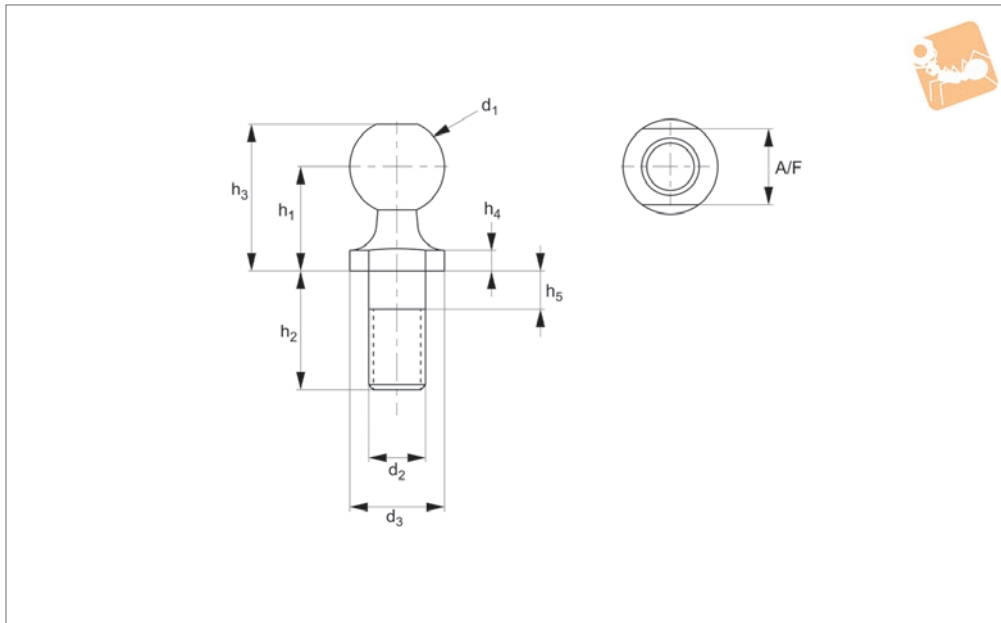

R3528

BALL & SOCKET JOINTS

Material

Stainless steel (AISI 304)

Technical Notes

To DIN 71803 Form C

*M14x1.5 is a fine pitch thread.

Order No.	d ₁ tol. H9	d ₂	d ₃ +0.0 -0.2	h ₁ ±0.3	h ₂ ±0.3	h ₃ ±0.3	h ₄ +0.4 -0.0	h ₅ max.	A/F	Weight g
R3528.005	8.0	M5	8.0	9.0	10.2	12.5	2.0	4.0	7.0	4.5
R3528.006	10.0	M6	10.0	11.0	12.5	15.5	2.2	4.0	8.0	8.5
R3528.008	13.0	M8	13.0	13.0	16.5	18.5	2.4	5.3	11.0	17.7
R3528.010	16.0	M10	16.0	16.0	20.0	23.0	2.7	7.3	13.0	35.0
R3528.012	16.0	M12	16.0	16.0	20.0	23.0	2.7	7.3	13.0	35.0
R3528.014	19.0	M14 x 1.5*	19.0	20.0	28.0	28.5	3.0	10.8	16.0	71.2
R3528.015	19.0	M14	19.0	20.0	28.0	28.5	3.0	10.8	16.0	71.2
R3528.016	19.0	M16	19.0	20.0	28.0	28.5	3.0	10.8	16.0	71.2

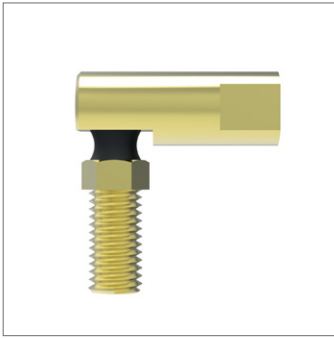

R3530

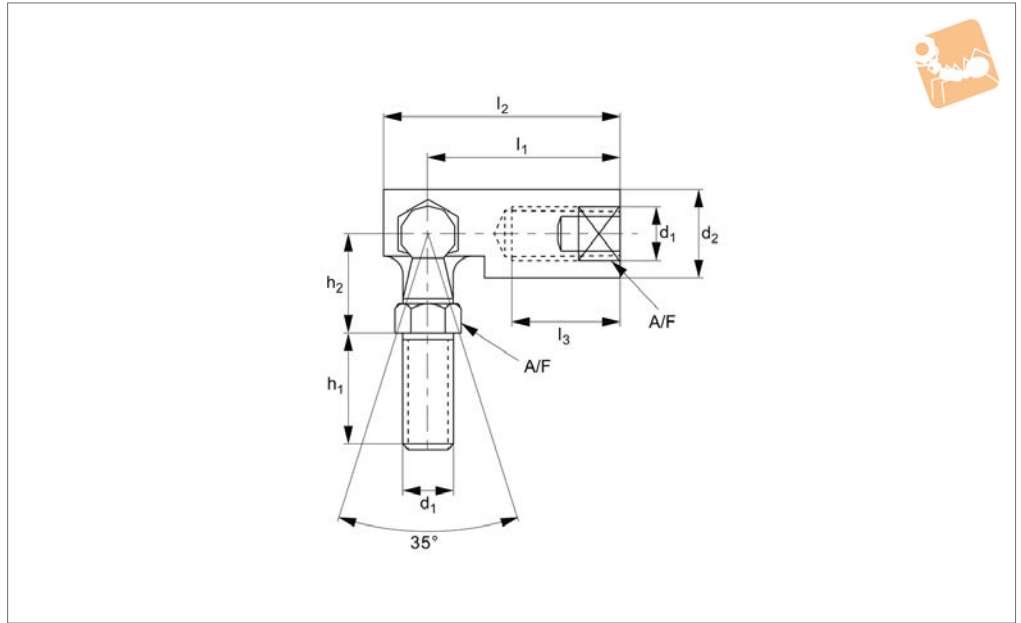

Material

Yellow zinc plated, ball stud is case hardened.
Body and ball stud low carbon steel (BS.970230M07Pb) or equivalent.

Technical Notes

The swaging of the body produces a permanent assembly and the fitted sealing cap helps resist dirt ingress.
The hexagon form of studs facilitates assembly, these are metric equivalents to

SAE J490 Style 1.

Tips

Standard thread is right hand thread.

Order No.	Thread hand	d ₁	d ₂	l ₁	l ₂	h ₁	h ₂	l ₃	A/F
R3530.R006	Right	M 6	11.13	24.61	30.96	14.30	11.91	12.70	9.53
R3530.R008	Right	M 8	12.70	28.58	35.71	17.48	13.49	14.30	11.13
R3530.R010	Right	M10	15.88	34.93	42.88	22.23	17.48	19.05	12.70
R3530.R012	Right	M12	19.05	49.23	60.33	28.58	22.23	25.40	15.88
R3530.L006	Left	M 6	11.13	24.61	30.96	14.30	11.91	12.70	9.53
R3530.L008	Left	M 8	12.70	28.58	35.71	17.48	13.49	14.30	11.13
R3530.L010	Left	M10	15.88	34.93	42.88	22.23	17.48	19.05	12.70
R3530.L012	Left	M12	19.05	49.23	60.33	28.58	22.23	25.40	15.88

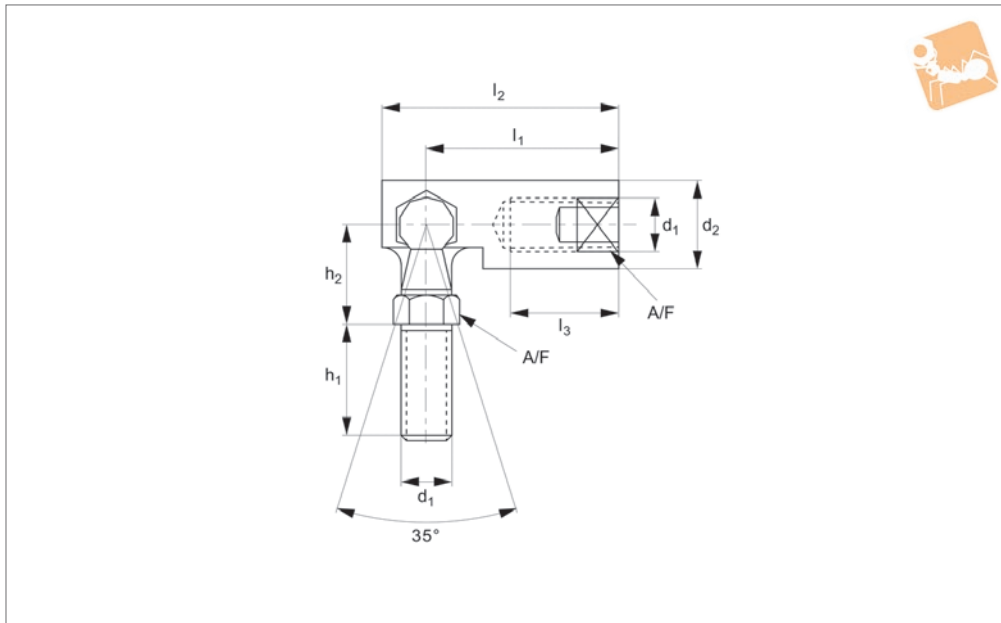

R3532

Material

Stainless steel (AISI 303).

Technical Notes

The swaging of the body produces a perma-

nent assembly and the fitted sealing cap helps resist dirt ingress.

The hexagon form of studs facilitates assembly.

Tips

Standard thread is right hand thread.

Order No.	Thread hand	d_1	d_2	l_1	l_2	h_1	h_2	l_3	A/F
R3532.R006	Right	M 6	11.13	24.61	30.96	14.30	11.91	12.70	9.53
R3532.R008	Right	M 8	12.70	28.58	35.71	17.48	13.49	14.30	11.13
R3532.R010	Right	M10	15.88	34.93	42.88	22.23	17.48	19.05	12.70
R3532.R012	Right	M12	19.05	49.23	60.33	28.58	22.23	25.40	15.88
R3532.L006	Left	M 6	11.13	24.61	30.96	14.30	11.91	12.70	9.53
R3532.L008	Left	M 8	12.70	28.58	35.71	17.48	13.49	14.30	11.13
R3532.L010	Left	M10	15.88	34.93	42.88	22.23	17.48	19.05	12.70
R3532.L012	Left	M12	19.05	49.23	60.33	28.58	22.23	25.40	15.88



R3538

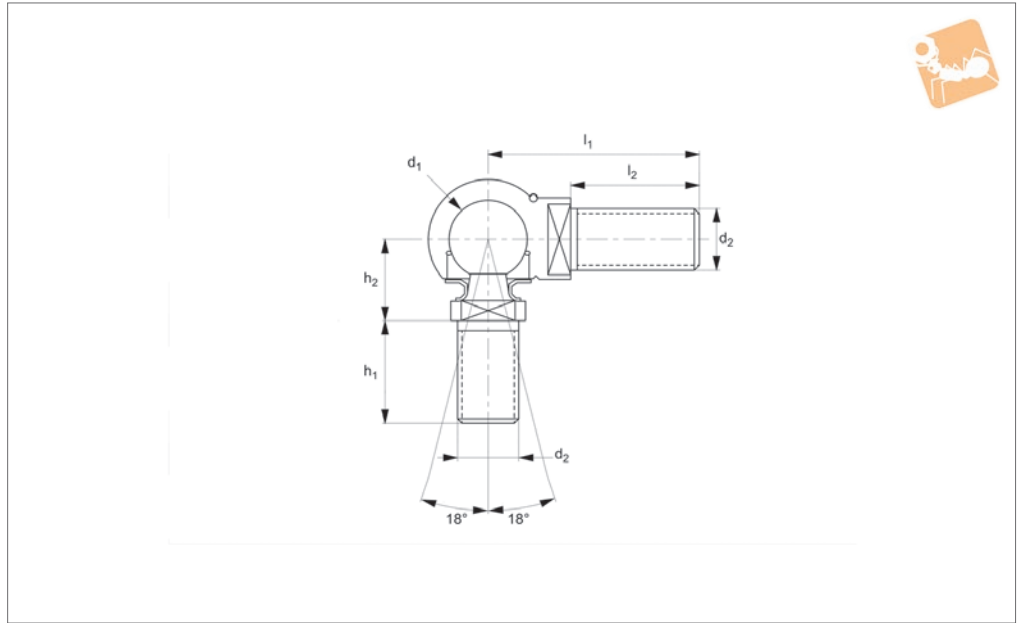

BALL & SOCKET JOINTS

Material

Low carbon steel, silver zinc plated.

stud in the housing.

Technical Notes

Safety ring aids the retention of the ball

Tips

Standard thread is right hand thread.

Order No.	Thread hand	d ₁	d ₂	l ₁	l ₂	h ₁	h ₂
R3538.R005	Right	8	M 5	22.5	12.0	10.2	9
R3538.R006	Right	10	M 6	25.0	13.5	12.5	11
R3538.R008	Right	13	M 8	31.5	17.5	16.5	13
R3538.R010	Right	16	M10	37.5	21.5	20.0	16
R3538.R012	Right	16	M12	42.0	25.5	20.0	16
R3538.L005	Left	8	M 5	22.5	12.0	10.2	9
R3538.L006	Left	10	M 6	25.0	13.5	12.5	11
R3538.L008	Left	13	M 8	31.5	17.5	16.5	13
R3538.L010	Left	16	M10	37.5	21.5	20.0	16
R3538.L012	Left	16	M12	42.0	25.5	20.0	16

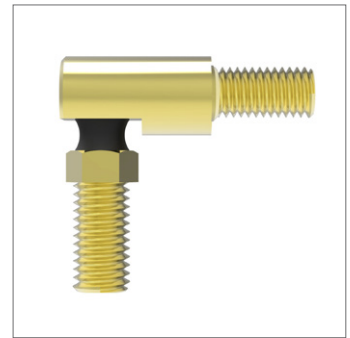
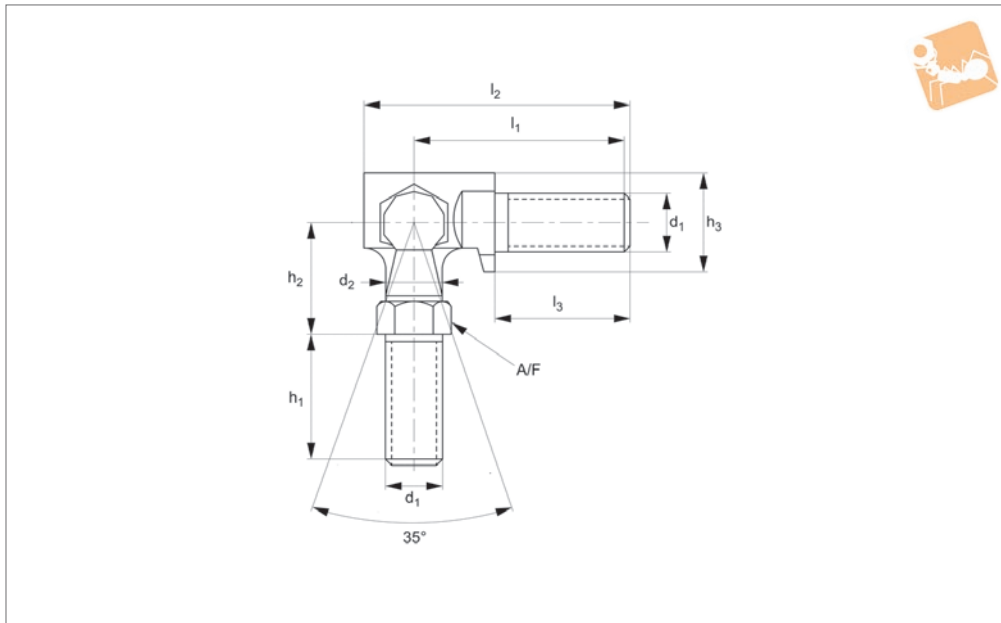

R3539

BALL & SOCKET JOINTS

Material

Low carbon steel (1018), yellow zinc plated.

Technical Notes

The swaging of the body produces a perma-

nent assembly and the fitted sealing cap helps resist dirt ingress. The hexagon form of studs facilitates assembly.

Tips

Standard thread is right hand thread.

Order No.	Thread hand	d ₁	d ₂	l ₁	l ₂	h ₁	h ₂	h ₃	l ₃	A/F
R3539.R005	Right	M 5	4.37	22.23	27.00	11.13	11.13	9.53	12.04	7.95
R3539.R006	Right	M 6	4.90	24.61	30.96	14.30	11.91	11.13	12.85	9.53
R3539.R008	Right	M 8	5.89	28.58	35.71	17.48	13.49	12.70	16.03	11.13
R3539.R010	Right	M10	7.54	34.93	42.88	22.23	17.48	15.88	19.05	12.70
R3539.R012	Right	M12	10.59	49.23	60.33	28.58	22.23	19.05	25.40	15.88
R3539.L005	Left	M 5	4.37	22.23	27.00	11.13	11.13	9.53	12.04	7.95
R3539.L006	Left	M 6	4.90	24.61	30.96	14.30	11.91	11.13	12.85	9.53
R3539.L008	Left	M 8	5.89	28.58	35.71	17.48	13.49	12.70	16.03	11.13
R3539.L010	Left	M10	7.54	34.93	42.88	22.23	17.48	15.88	19.05	12.70
R3539.L012	Left	M12	10.59	49.23	60.33	28.58	22.23	19.05	25.40	15.88

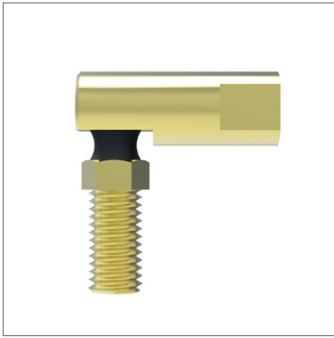

R3530.i

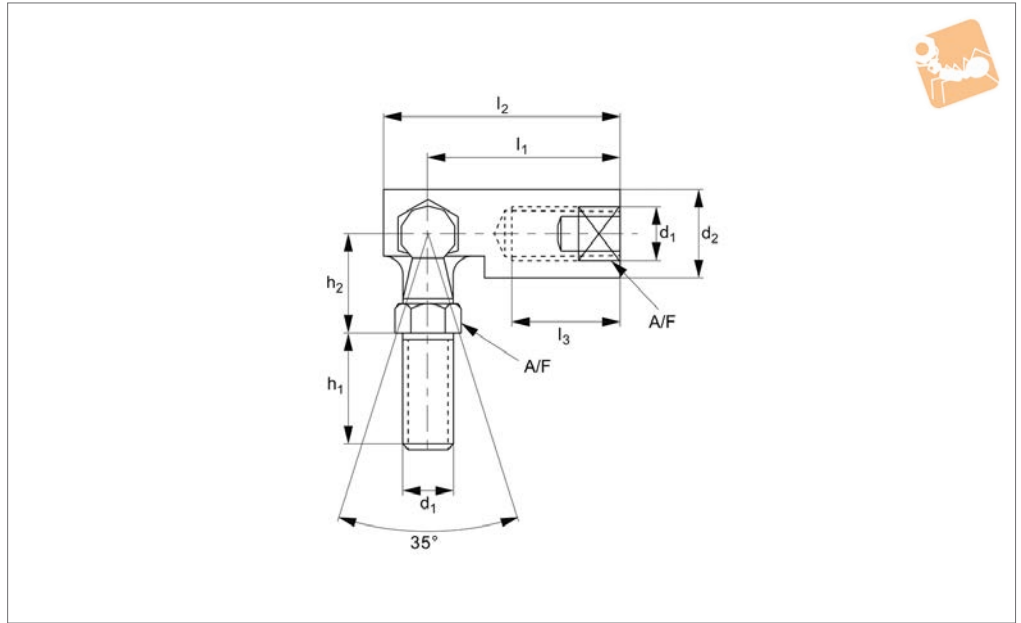

Material

Yellow zinc plated steel, ball stud is case hardened.

Technical Notes

The swaging of the body produces a permanent assembly and the fitted sealing cap helps resist dirt ingress.

The hexagon form of studs facilitates assembly, yellow zinc is not RoHS Compliant.

Tips

Standard Thread is Right hand thread, equivalent to Springfix DIG joints.

Order No.	Thread hand	d ₁	d ₂	l ₁	l ₂	h ₁	h ₂	l ₃	A/F
R3530.I187	Right	10-32	0.375	0.875	1.063	0.438	0.438	0.438	0.313
R3530.I250	Right	1/4-28	0.438	0.969	1.219	0.563	0.469	0.500	0.375
R3530.I312	Right	5/16-24	0.500	1.125	1.406	0.688	0.531	0.563	0.438
R3530.I375	Right	3/8-24	0.625	1.375	1.688	0.875	0.688	0.750	0.500
R3530.I438	Right	7/16-20	0.750	1.938	2.375	1.125	0.875	1.000	0.625
R3530.I500	Right	1/2-20	0.750	1.938	2.375	1.125	0.875	1.000	0.625
R3530.I625	Right	5/8-18	0.875	2.063	2.578	1.125	1.000	1.000	0.750
R3530.IL187	Left	10-32 LH	0.375	0.875	1.063	0.438	0.438	0.438	0.313
R3530.IL250	Left	1/4-28 LH	0.438	0.969	1.219	0.563	0.469	0.500	0.375
R3530.IL312	Left	5/16-24 LH	0.500	1.125	1.406	0.688	0.531	0.563	0.438
R3530.IL375	Left	3/8-24 LH	0.625	1.375	1.688	0.875	0.688	0.750	0.500
R3530.IL438	Left	7/16-20 LH	0.750	1.938	2.375	1.125	0.875	1.000	0.625
R3530.IL500	Left	1/2-20 LH	0.750	1.938	2.375	1.125	0.875	1.000	0.625
R3530.IL625	Left	5/8-18 LH	0.875	2.063	2.578	1.125	1.000	1.000	0.750

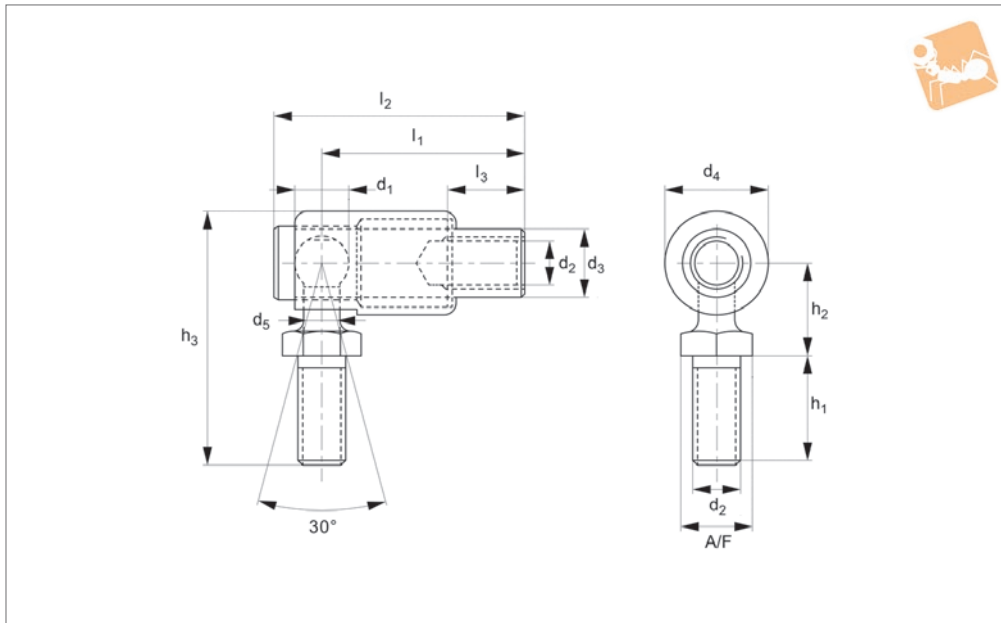

R3535.i

BALL & SOCKET JOINTS

Material

Silver/Clear zinc plated steel

Technical Notes

The spring loaded outer shield allows both

rapid release and reconnection of the ball stud.

Linkage assemblies can be installed or removed without disturbing pre-set

centres.

Tips

Equivalent to Springfix QI ball joints

Order No.	d ₁	d ₂	l ₁	l ₂	d ₃	d ₄	d ₅	h ₁	h ₂	h ₃	l ₃	A/F
R3535.I187	0.250	10-32	0.906	1.094	0.310	0.438	0.171	0.438	0.438	1.125	0.438	0.312
R3535.I250	0.311	1/4-28	0.969	1.250	0.370	0.562	0.194	0.562	0.469	1.312	0.531	0.375
R3535.I312	0.339	5/16-24	1.125	1.453	0.439	0.687	0.228	0.625	0.531	1.594	0.605	0.437
R3535.I375	0.421	3/8-24	1.375	1.750	0.556	0.875	0.269	0.750	0.687	1.969	0.812	0.500

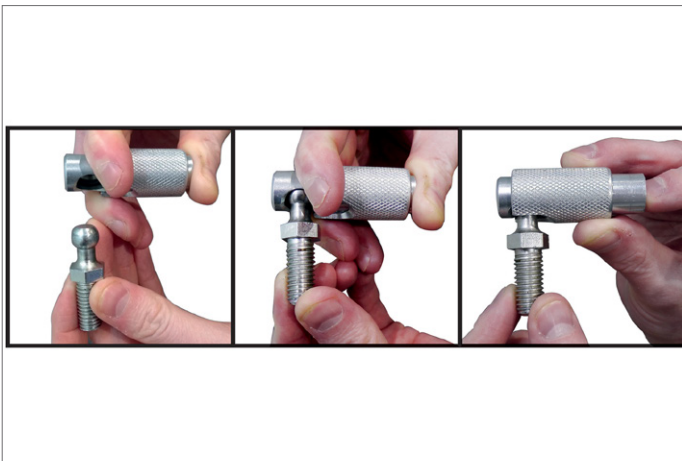

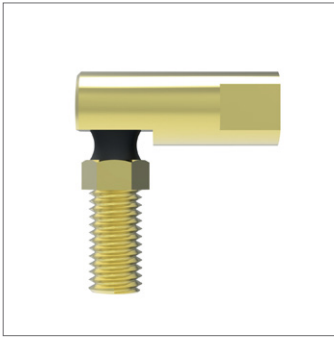

R3536.i

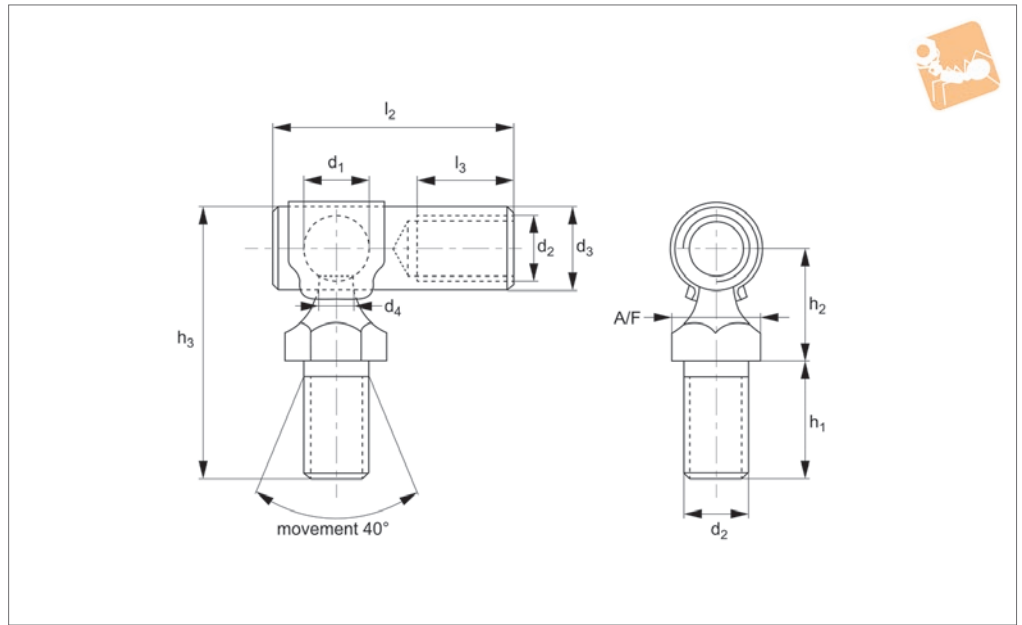

Material

Yellow zinc plated steel.

Technical Notes

Quick disconnect ball joints are used in light duty applications where the ball stud

needs to be easily disconnected from the housing. This is accomplished simply by pulling the ball stud out of the housing, (takes approximately 10 to 20 pounds of

force to remove the ball stud). Quick disconnect ball joints are typically assembled in push-pull cables or rod linkages.

Order No.	d ₁	d ₂	l ₁	l ₂	d ₃	d ₄	h ₁	h ₂	h ₃	l ₃	A/F	Weight g
R3536.3-4	0.250	10-32	0.875	1.156	0.312	0.138	0.437	0.420	1.032	0.484	0.312	1300
R3536.4-4	0.250	10-32	0.875	1.156	0.312	0.138	0.562	0.420	1.156	0.484	0.312	1400
R3536.4-3	0.250	1/4	0.969	1.250	0.312	0.138	0.562	0.420	1.156	0.531	0.312	1300
R3536.4L-4L	0.250	1/4	0.969	1.250	0.312	0.138	0.437	0.420	1.032	0.531	0.312	1200
R3536.3-3	0.312	5/16	0.875	1.187	0.394	0.177	0.562	0.537	1.312	0.484	0.437	7200



Quick Release Ball Joints

A2 stainless and steel, zinc-plated

Ball & Socket Joints

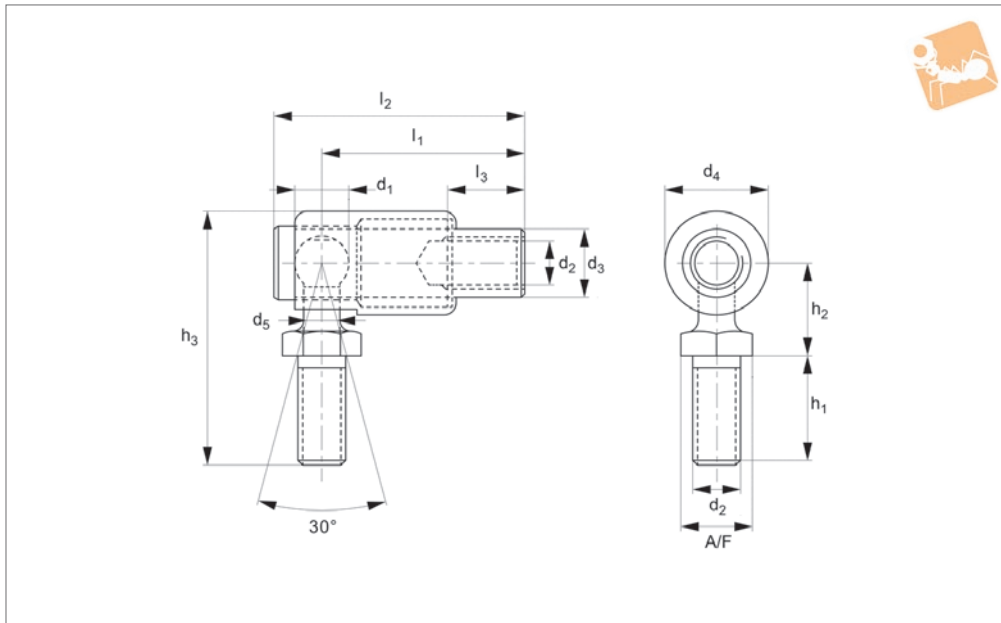

R3535

BALL & SOCKET JOINTS

Material

Body: stainless steel (A2, AISI 303) or steel zinc-plated.

Shield and ball stud: carbon steel.

Body and ball stud: case hardened.

Spring: (302 S26) stainless steel or equivalent, zinc plated.

Technical Notes

The spring loaded outer shield allows both rapid release and reconnection of the ball stud.

Linkage assemblies can be installed or removed without disturbing pre-set centres.

These are metric equivalents to SAE J 490 Style 1 quick release detachable ball joints.

Tips

Standard thread is a right hand thread.

Order No.	Thread hand	d ₁	d ₂	l ₁	l ₂	d ₃	d ₄	d ₅	h ₁	h ₂	h ₃	l ₃	A/F	Weight g
R3535.005-ZP	Right	6.35	M 5	23.0	28	7.9	11.1	4.35	11.1	11.9	28.6	11.1	8	17
R3535.006-ZP	Right	7.9	M 6	24.6	30	9.4	13.0	4.95	12.6	12.6	33.4	13.0	10	25
R3535.008-ZP	Right	8.6	M 8	31.7	40	11.1	16.0	5.8	15.2	15.2	40.6	14.3	11	48
R3535.010-ZP	Right	10.7	M10	39.7	49	14.1	19.0	6.85	19.8	19.8	51.4	27.0	13	78
R3535.011-ZP	Right	10.7	M10	39.7	49	14.1	19.0	6.85	19.8	19.8	51.4	20.0	13	78
R3535.005-A2	Right	6.35	M 5	23.0	28	7.9	11.1	4.35	11.1	11.9	28.6	11.1	8	17
R3535.006-A2	Right	7.9	M 6	24.6	30	9.4	13.0	4.95	12.6	12.6	33.4	13.0	10	25
R3535.008-A2	Right	8.6	M 8	31.7	40	11.1	16.0	5.8	15.2	15.2	40.6	14.3	11	48
R3535.010-A2	Right	10.7	M10	39.7	49	14.1	19.0	6.85	19.8	19.8	51.4	27.0	13	78
R3535.011-A2	Right	10.7	M10	39.7	49	14.1	19.0	6.85	19.8	19.8	51.4	20.0	13	78

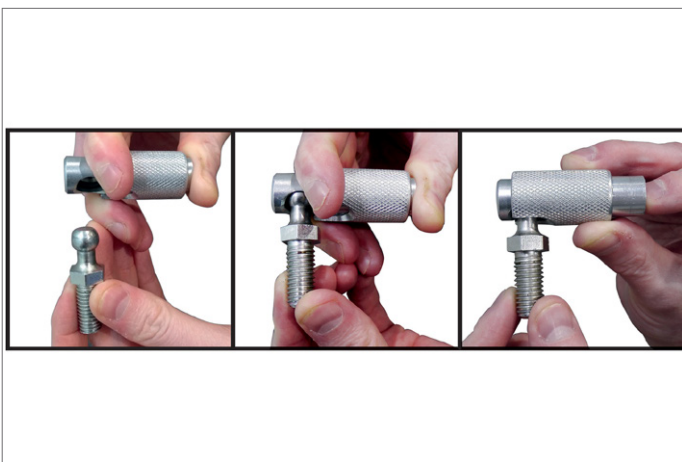

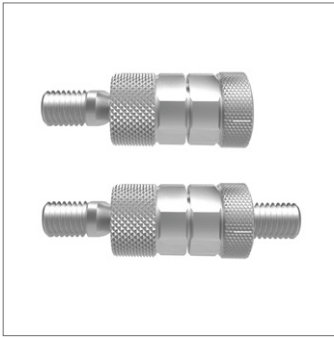

R3540

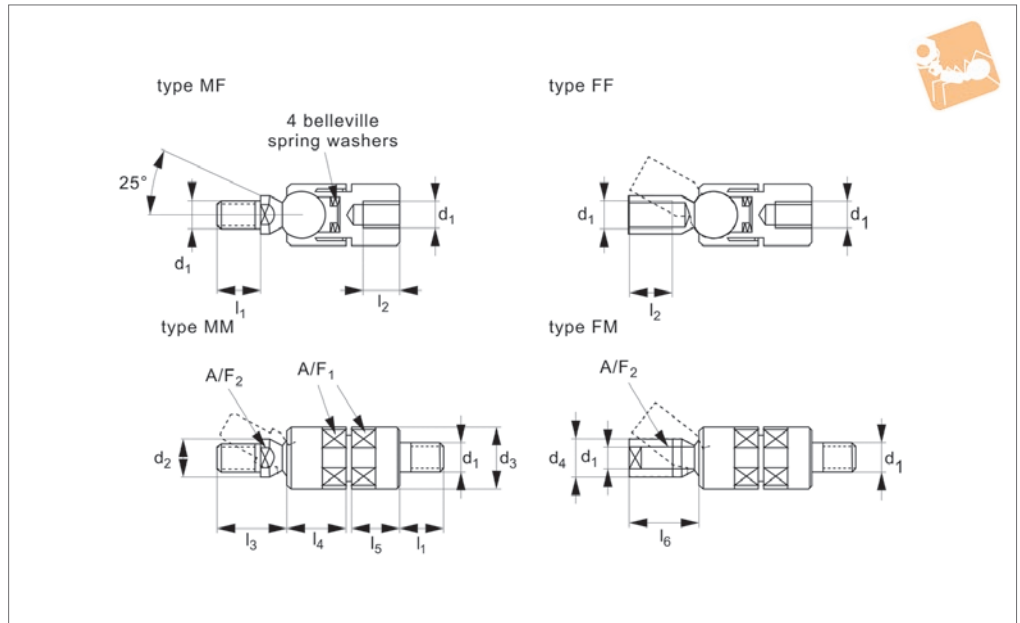

Material

Steel, (silver zinc plated). Brake piece technopolymer (polyamide PA).

Technical Notes

The clamping nut can be set to give a

required thrust on the Belleville spring washers, in order to increase resistance to the movement of the ball stud, the spring washers act as safety washers for the

screws.

Once the max. thrust to the spring washers is reached the ball stud is firmly fixed in position.

Order No.	Type	d ₁	l ₁	d ₂	d ₃	l ₂	l ₃	l ₄	l ₅	l ₆	A/F ₁	A/F ₂
R3540.MF008	MF	M8	12	11	19	10	19.5	18.5	15	-	17	9
R3540.MF010	MF	M10	15	13	21	12	23.5	21.5	17	-	19	11
R3540.MM008	MM	M8	12	11	19	-	19.5	18.5	15	-	17	9
R3540.MM010	MM	M10	15	13	21	-	23.5	21.5	17	-	19	11
R3540.FF008	FF	M8	-	11	19	10	19.5	18.5	15	-	17	9
R3540.FF010	FF	M10	-	13	21	12	23.5	21.5	17	-	19	11
R3540.FM008	FM	M8	12	11	19	-	19.5	18.5	15	18.5	17	9
R3540.FM010	FM	M10	15	13	21	-	23.5	21.5	17	20.5	19	11