

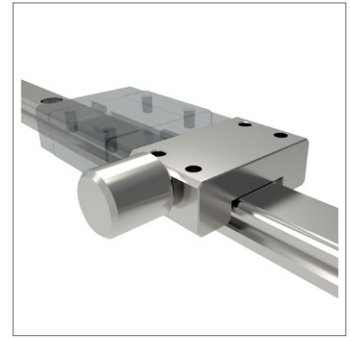

Manual Clamps for Miniature Rail for L1010 and L1012

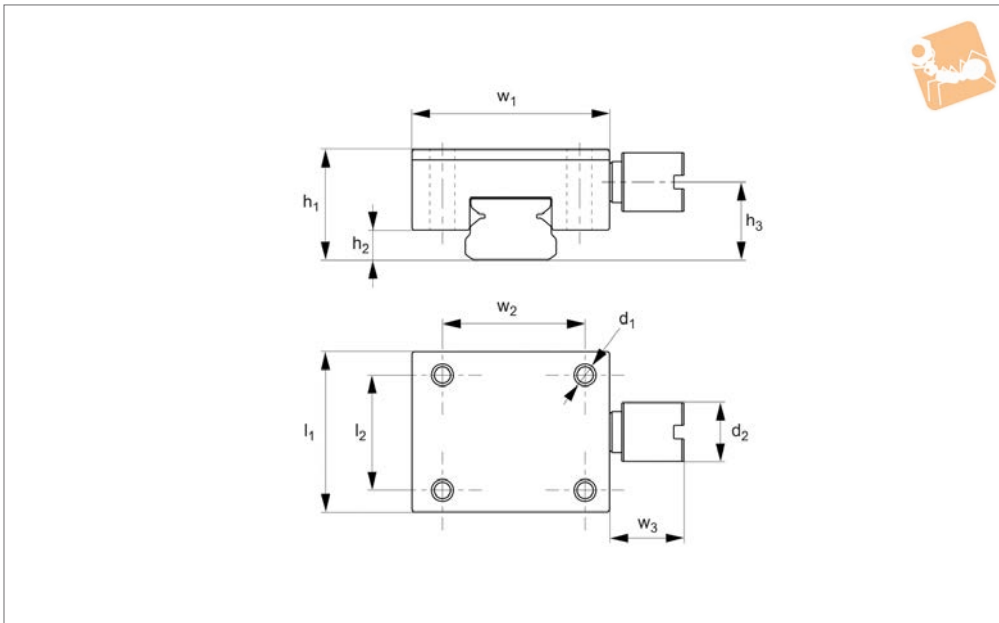

L1010.CL



Material

Corrosion resistant stainless steel, hardened (similar to 440C).

Technical Notes

The manual rail clamps are used alongside the rail carriges. Activating the clamping

knob presses the clamp contact surfaces onto the rail, clamping it in place.

Order No.	For rail	h_1	l_1	w_1	h_2	h_3	l_2	w_2	w_3	d_1	d_2	Holding force kgf	Torque to Nm
L1010.CL07	L1010.07	8	12	17	2	4.3	8	12	7	M2	6	65	0.11
L1010.CL09	L1010.09	10	17	20	2.7	5.35	11	15	9	M3	8	100	0.17
L1010.CL12	L1010.12	13	19	27	3.5	7.15	13	20	10	M3	10	150	0.35
L1010.CL15	L1010.15	16	20	32	5	8.05	14	25	14	M3	12	180	0.75
L1012.CL14	L1012.14	9	12	25	3	4.3	8	19	6.65	M2	6	65	0.10
L1012.CL18	L1012.18	12	17	30	4.2	5.85	11	23	9	M3	8	100	0.17
L1012.CL24	L1012.24	14	19	40	4	7.65	13	30	10	M3	10	150	0.35
L1012.CL42	L1012.42	16	22	60	4.5	8.55	15	45	14.7	M4	12	180	0.75



Miniature linear guideway systems are widely used throughout industry for precise, compact applications.

Precise and stainless

The gothic arch shape of the rails have a 45° contact ensuring similar load capacities in all directions. Use of a large number of stainless steel balls enables a high moment and load capacity within a compact space. These smooth running rails have low break-away forces and a low coefficient of friction.

LINEAR GUIDEWAYS

Stainless steel

Anti-corrosion for use in scientific, medical and pharmaceutical applications.

Standard and wide versions

Our standard width is a compact, high performance rail in six sizes.

The wide version can generally accept higher loads and moment forces, and as a result are especially suited for single rail applications.

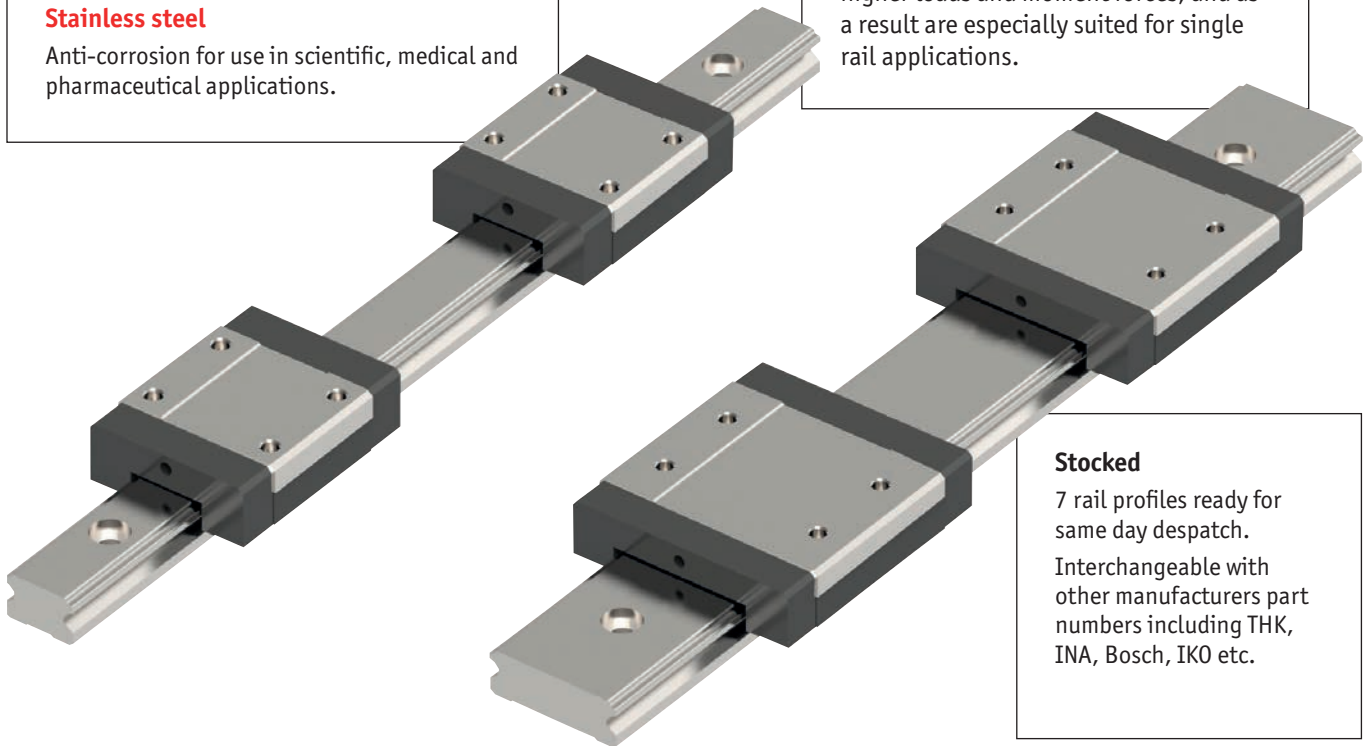

Stocked

7 rail profiles ready for same day despatch.

Interchangeable with other manufacturers part numbers including THK, INA, Bosch, IKO etc.

Rail sizes

L1010 Standard Version



L1012 Wide Version

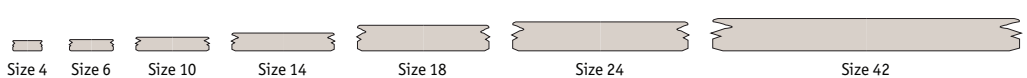



Load capacities – explained

- A number of load figures are stated for load capacity:

Dynamic loads – this is the main figure considered for miniature linear guideways. It is the moving load that the system can bear. It takes account of the total moving load as well as considerations such as impact, vibration and fatigue.

Static loads – this is a load that is constant for an extended time (i.e. the dead load the system can bear before any movement). It can be in tension or compression.

For these miniature linear guideways the radial and axial load capacities are the same.

Moment loads are twisting loads generated by offset loads in either X, Y or Z planes. Moment loads can be reduced by adding further carriages or rails to reduce any twisting of the carriage due to the load offset.

Why is there a standard width and a wide version rail?

- The wider version system is generally used as a single rail system as it can accept higher loads and moment loads, whilst maintaining a very low height.
- The standard width rail can be used either as stand-alone rails or are more frequently used as a pair of rails in parallel.

Straightness of rails

- The measurements of the straightness of the system are taken from the running accuracy of the sliders over the length of the rails (given in microns) – see accuracy and preload page. For standard accuracy this equates to around 15µ for a 300mm length, increasing to 25µ for a 1 metre length.

What lengths can be provided?

- We have standard rail lengths. These are based on the hole pitch of the rails and end machining to provide an equidistant length to the first and last hole centre.
- However we can cut the rail (from stock) to any length required – we just need to know the distance required for the first hole.
- In general our cutting procedures allow for a $\pm 2\text{mm}$ accuracy on the overall rail length. If greater accuracy than this is required then we have to machine the end accurately (rather than cut it) and this involves extra time and cost.
- Standard maximum length for each rail size is around 1 metre. Rails can be joined together but the preparation needs to be made in our workshop. The rails will be marked clearly with the ends to be placed adjacent to each other.

Installation

- The miniature linear guideways are very accurate and as a result need to be installed on accurately prepared surfaces - please see installation instructions. If two rails are installed in parallel, they need to be precisely aligned - see assembly precision page.

Mounting the carriages to the rails

- In general the carriages will be supplied separately to the rails. The carriages are supplied mounted on plastic “dummy” blocks. To install the carriage onto the rails, offer the carriage (still on its dummy block) up to the rails and slide off the dummy block and onto the rail itself.

Do not simply remove the carriage from the dummy block, as some of the bearings might become displaced, rendering the carriage unusable.

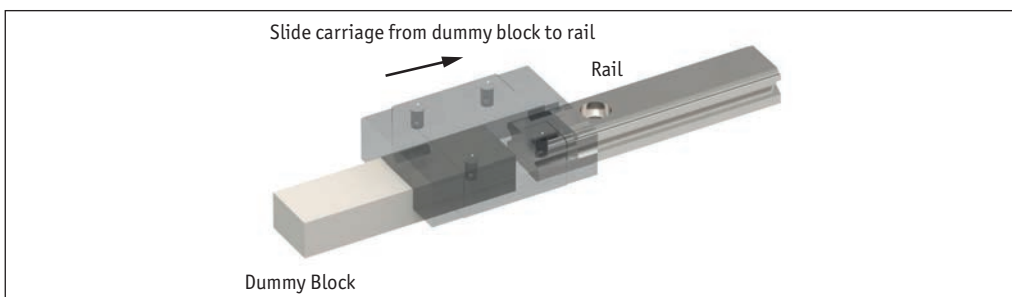



Precision

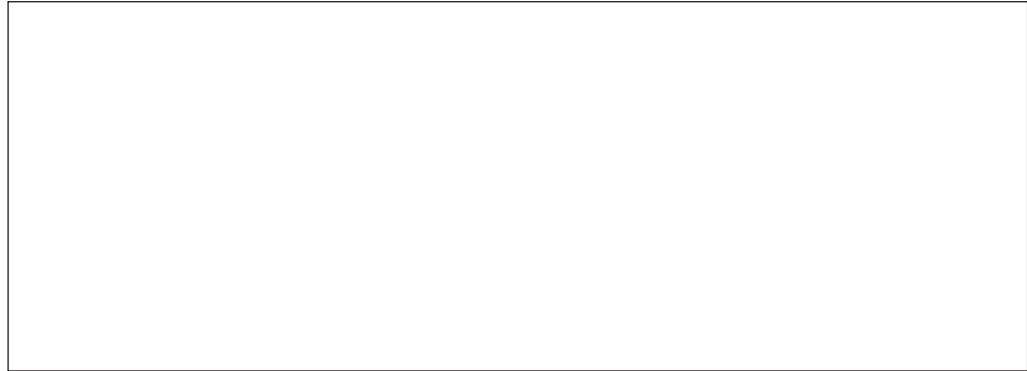

	Dimensions	μ
h_1	Height tolerance h_1	± 40
h_1	Permissible height difference of different carriages at the same position on the rail	25
W_4	Width tolerance w_4	± 40
W_4	Permissible width difference of different carriages at the same position on the rail	30

Running accuracy

Preload

The miniature linear guideways are available in the two different preload classes K_0 and K_5 . The preload influences the rigidity, precision and torque resistance as well as offering the product service life and displacement force. The standard preload is K_0 .

Type	Preload classes	
	Small K_0	Standard K_5
	Very quiet running (μ)	Quiet and precise running (μ)
L1010.03 & L1012.06	+3 to 0	+1 to 0
L1010.05 & L1012.10	+3 to 0	+1 to 0
L1010.07 & L1012.14	+4 to 0	+2 to 0
L1010.09 & L1012.18	+4 to 0	+2 to 0
L1010.12 & L1012.24	+5 to 0	+2 to 0
L1010.15 & L1012.42	+6 to 0	+3 to 0



L1010 - Standard width

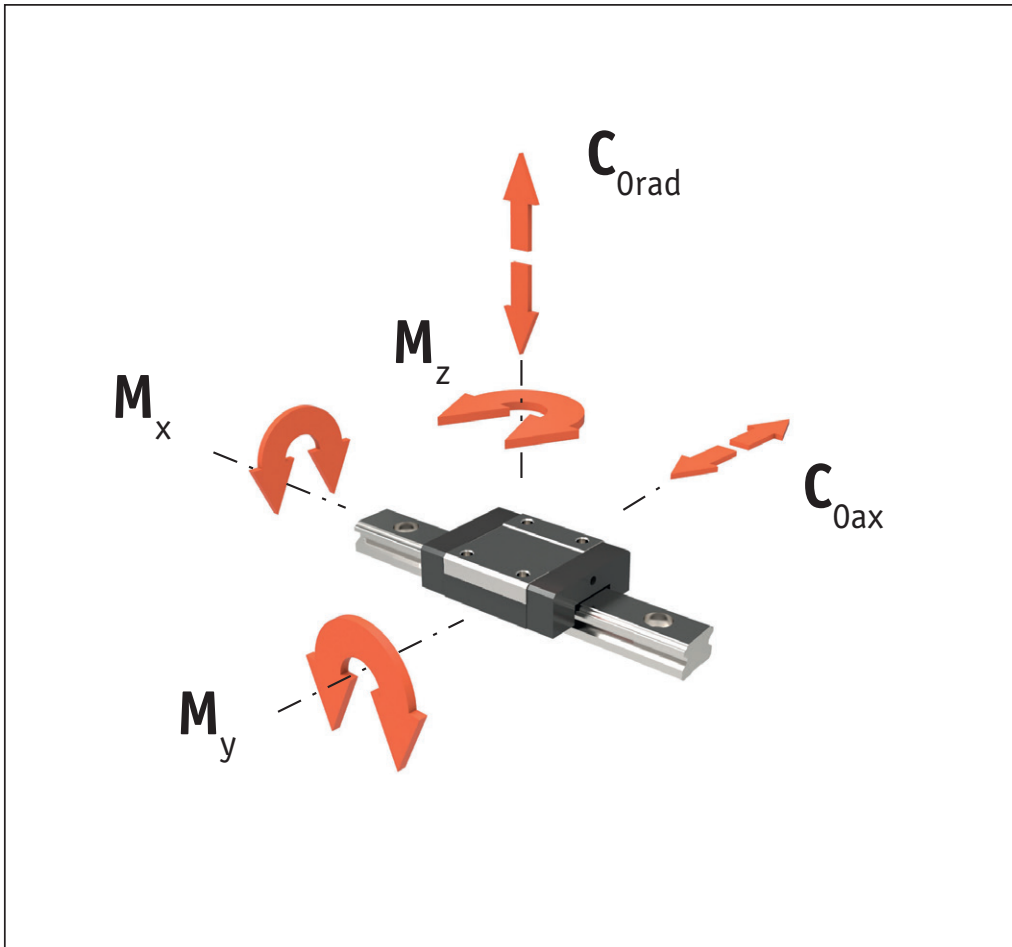

Miniature Linear Guideways from Automation Components

LINEAR GUIDEWAYS

Type	Max. load capacities		Max. static moment loads		
	dyn. C_{rad} & C_{ax} N	stat. C_{0rad} & C_{0ax} N	M_x Nm	M_y Nm	M_z Nm
L1010.C03	190	310	0,6	0,4	0,4
L1010.C03L	295	575	0,9	1,1	1,1
L1010.C05	335	550	1,7	1,0	1,0
L1010.C05L	470	900	2,4	2,1	2,1
L1010.C07	890	1400	5,2	3,3	3,3
L1010.C07L	1310	2440	9,0	7,7	7,7
L1010.C09	1570	2495	11,7	6,4	6,4
L1010.C09L	2135	3880	18,2	12,4	12,4s
L1010.C12	2308	3465	21,5	12,9	12,9
L1010.C12L	3240	5630	34,9	30,2	30,2
L1010.C15	3810	5590	43,6	27,0	27,0
L1010.C15L	5350	9080	70,0	63,0	63,0