

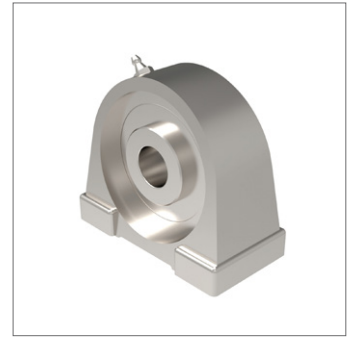

Stainless Pillow Block Bearing Units

blind holes

Bearing Mounts

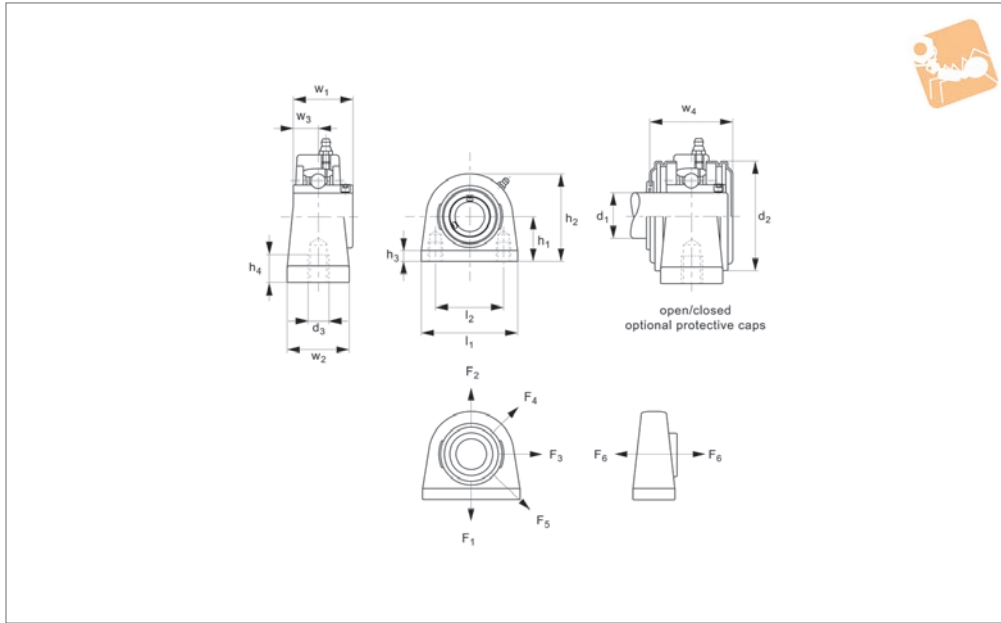

L1871

BEARING MOUNTS

Material

Stainless steel (AISI 304), with smooth surfaces. Bearing stainless steel (440C) with 2RS seals, lubricated with food grade grease (USDA approved).

Technical Notes

Self-aligning bearing units.

Temperature range for bearings: -15°C to +120°C.

Resistant to a moisture and a wide range of aggressive chemicals.

For shaft end caps add suffixes:

- CO for open (with seal)
- CC for closed.

Tips

Shaft retention with two set screws (at 120° offset).

Used with h6 tolerance shafts (see our part no.s L1770-L1776).

Maximum housing loads measured @ 20°C.

Order No.	d ₁ for h6	l ₁	d ₂	d ₃	h ₁	h ₂ +0 -0.8	h ₃	h ₄	l ₂	w ₁	w ₂	w ₃	w ₄	Weight kg
L1871.012	12	73	M 8	50.8	54	11	13	31.0	65	38	12.7	45.6	0.73	33.3
L1871.015	15	73	M 8	50.8	54	11	13	31.0	65	38	12.7	45.6	0.71	33.3
L1871.017	17	73	M 8	50.8	54	11	13	31.0	65	38	12.7	45.6	0.70	33.3
L1871.020	20	73	M 8	50.8	54	11	13	31.0	65	38	12.7	45.6	0.68	33.3
L1871.025	25	76	M10	50.8	60	11	13	34.1	71	38	14.3	47.8	0.78	36.5
L1871.030	30	102	M10	76.2	70	12	16	38.1	86	38	15.9	52.8	1.30	42.9
L1871.035	35	108	M10	82.6	80	12	19	42.9	95	48	17.5	57.4	1.72	47.6
L1871.040	40	117	M12	89.0	88	13	19	42.9	100	48	19.0	66.8	1.91	49.2
L1871.045	45	127	M12	95.3	95	13	19	49.2	108	51	19.0	67.8	2.33	54.0
L1871.050	50	140	M16	101.6	100	13	19	51.6	117	51	19.0	75.6	2.83	57.2

Order No.	Speed rpm	Dyn. load C kN max.	Static bearing load C ₀ kN max.	Housing load F ₁ kN max.	Housing load F ₆ kN max.	Housing load F ₂ kN max.	Housing load F ₃ kN max.	Torque screw to Nm	Housing load F ₄ kN max.	Housing load F ₅ kN max.	Set screw size
L1871.012	4800	10.1	6.8	160	34	66	110	8.5	50	160	M 6x1
L1871.015	4800	10.1	6.8	160	34	66	110	8.5	50	160	M 6x1
L1871.017	4800	10.1	6.8	160	34	66	110	8.5	50	160	M 6x1
L1871.020	4800	10.1	6.8	160	34	66	110	8.5	50	160	M 6x1
L1871.025	4000	11.0	8.0	180	36	74	120	20	56	180	M 8x1
L1871.030	3400	15.3	11.5	240	44	100	180	20	70	240	M 8x1
L1871.035	3000	20.1	15.6	320	48	120	200	40	88	320	M 10x1,25



Order No.	Speed rpm	Dyn. load C kN max.	Static bearing load C ₀ kN max.	Housing load F ₁ kN max.	Housing load F ₆ kN max.	Housing load F ₂ kN max.	Housing load F ₃ kN max.	Torque screw to Nm	Housing load F ₄ kN max.	Housing load F ₅ kN max.	Set screw size
L1871.040	2600	22.8	18.2	360	50	130	220	40	90	360	M 10x1,25
L1871.045	2400	25.7	20.8	380	52	140	240	40	98	380	M 10x1,25
L1871.050	2200	27.5	23.7	380	64	150	280	40	110	380	M 10x1,25



Bearing Supports from Automation Components

Housing material options



Cast iron housing

Standard version, passivated and painted $\varnothing 12-120\text{mm}$.

Stainless steel housing

Stainless AISI 304, $\varnothing 12-60\text{mm}$.

Thermoplastic housing

Food grade applications, smooth PBT resin material, $\varnothing 20-40\text{mm}$.

Pillow Bearings

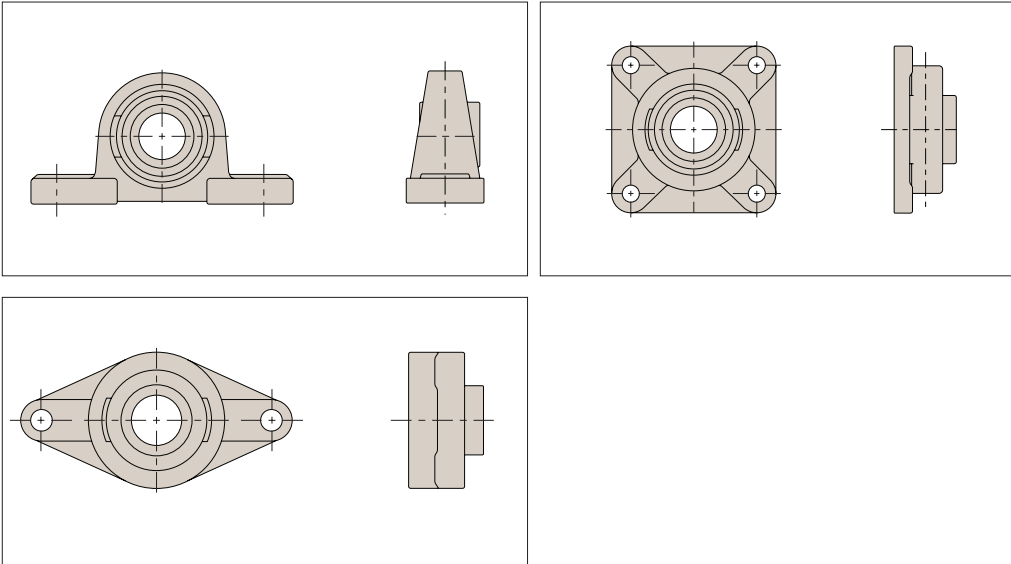

Use with Automation linear shafts L1770-L1774

Options

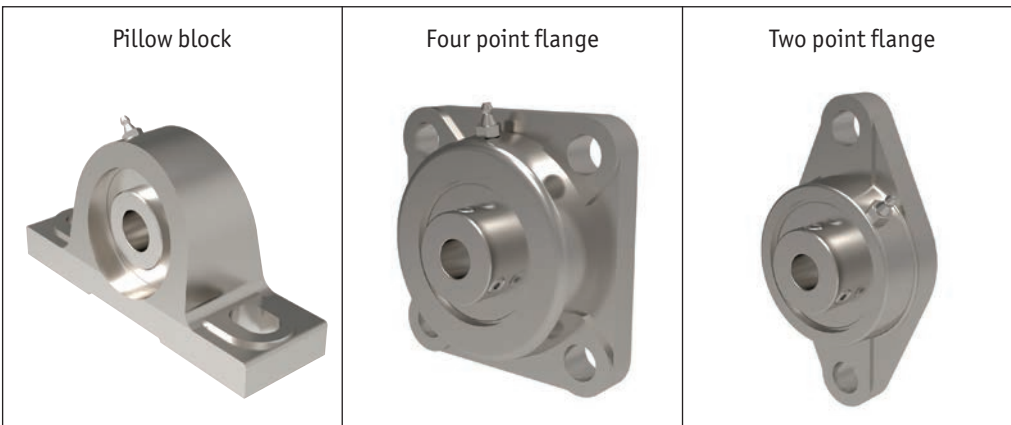



For cast iron housings

- Single row radial contact self-aligning bearings (steel 100Cr6).
- Re-lubricatable.
- Fixing to shaft via set screw.
- Operating temperature range -20° to $+100^{\circ}$.

For stainless & thermoplastic housings

- Single row radial contact self-aligning bearings (stainless steel AISI 440C), stainless steel cage.
- Lubricated with food grade grease.
- Fixing to shaft via set screw.

Shaft fixing set screw

2 set screws at 120° with hexagon socket and knurled cup point, recommended shaft tolerance h6/h7.

Set screw	Max. tightening torque (Nm)	Hexagon socket A/F
M5 x 0,8	3,5	2,5
M6 x 1	5,5	3,0
M8 x 1	11,5	4,0
M10 x 1,25	22,0	5,0
M12 x 1,25	33,0	6,0
M14 x 1,5	42,0	7,0
M16 x 1,5	64,0	8,0
M18 x 1,5	75,0	9,0
M20 x 1,5	120,0	10,0

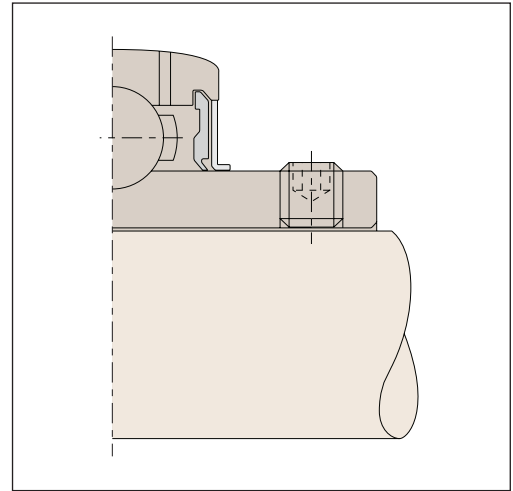

Lubrication

Our units are lubricated for life. If re-lubrication is necessary (because of severe operating conditions), use a lithium soap base with a viscosity of $100\text{mm}^2/\text{s}$ at 40°C .

Installation

Shaft misalignment is compensated to a certain degree by the shaft-aligning bearings.

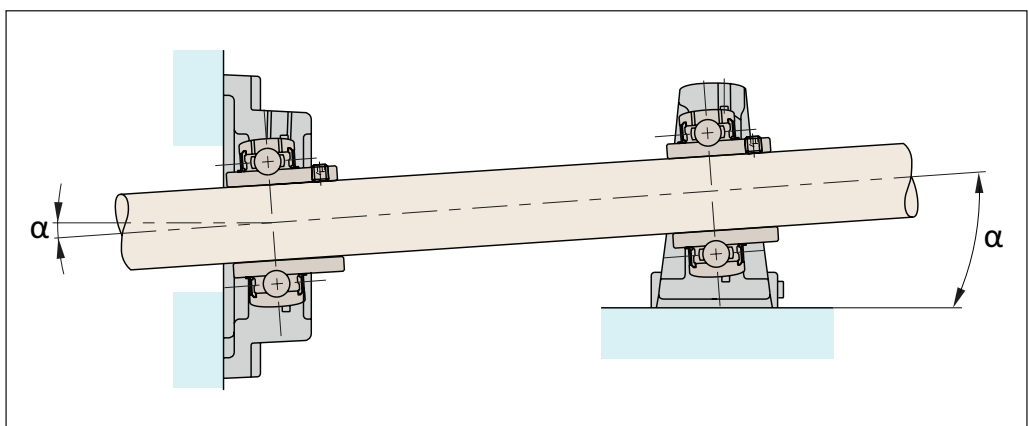

If re-lubrication required

$$\alpha = \pm 2^{\circ}$$

If no re-lubrication

$$\alpha = \pm 5^{\circ}$$

When using protective end caps

$$\alpha = \pm 5^{\circ}$$



Cast Iron Bearing Units

Equivalent load ratings

Bearing Support Units



The radial loads of the cast iron bearing supports are limited by the bearings themselves – the housings can withstand the maximum loads.

Please see the part numbers for dynamic and static radial loads. The maximum axial loads are 50% of the maximum static radial loads. The standard bearing have a C3 clearance.

Bore nominal size (mm)		Radial bearing clearance (μ) C3	
Above	Up to	Min.	Max.
10	18	11	25
18	24	13	28
24	30	13	28
30	40	15	33
40	50	18	36
50	65	23	43
65	80	25	51
80	100	30	58
100	120	36	66
120	140	41	81

When choosing a suitable bearing size – this depends on the load and speed required.

If the load acts mainly whilst the bearing rotates, then it is a dynamic load, if it acts mainly during no movement or low speeds, then it is a static load.

The maximum for both of these, for each bearing, is shown in the part tables.

Bearing Supports from Automotion Components

BEARING MOUNTS

Dynamic equivalent loads:

For some situations the bearing will have to withstand both radial and axial loads and we then need to calculate an equivalent dynamic load using the following equation:

$$L = X \cdot F_r + Y \cdot F_a \text{ (kN)}$$

- P = Dynamic equivalent load (kN)
- F_r = Actual radial load (kN)
- F_a = Actual axial load (kN)
- X = Radial factor
- Y = Axial factor

Load ratio table 1:

F_a C_{0r}	e	$\frac{F_a}{F_r} \leq e$		$\frac{F_a}{F_r} > e$	
		X	Y	X	Y
0,014	0,19				2,30
0,028	0,22				1,99
0,056	0,26				1,71
0,084	0,28				1,55
0,110	0,30	1	0	0,56	1,45
0,170	0,34				1,31
0,280	0,38				1,15
0,420	0,42				1,04
0,560	0,44				1,00

e = Limiting value

C_{0r} = Radial static load rating (see dimension tables for ball bearing units)



Static equivalent loads

For situations where there are radial and axial loads on the static or slow moving bearings:

$$P_0 = X_0 \cdot F_r + Y_0 \cdot F_a \text{ (kN)}$$

$$P_0 = F_r \quad \text{if} \quad \frac{F_a}{F_r} \leq 0.8$$

P_0 = Static equivalent load (kN) For all bearing inserts the following applies:
 X_0 = Static radial factor $X_0 = 0.6$
 Y_0 = Static axial factor $Y_0 = 0.5$

Using the ratio **fs**, it can be checked if sufficient static dimensioning for the insert has been ensured:

$$fs = \frac{C_{0r}}{P_0}$$

Some standard values are:

- fs** = 0.7 Minimal demands for running smoothness and rotating movement
- fs** = 1.0 occasional rotating bearing, normal demands for running
- fs** = 2.0 smoothness, high demands for running smoothness

It should be noted that this ratio does not provide any assurance against a break or similar, but instead it is assurance against excessive local deformation in the rolling contact (ball/raceway).

Calculating bearing life

When calculating bearing life for bearing units, the following applies:

$$L_{10} = \left(\frac{C_r}{p} \right)^3 \quad \text{(10}^6 \text{ revolutions)}$$

If the bearing life should be specified in hours, the following applies:

$$L_{10h} = \left(\frac{C_r}{p} \right)^3 \cdot \frac{10^6}{60n} \quad \text{(h)}$$

n = speed (min⁻¹)