



# Medium Duty Sliders, size 35

side seal, front fixing, with wiper



## Long Linear Rails

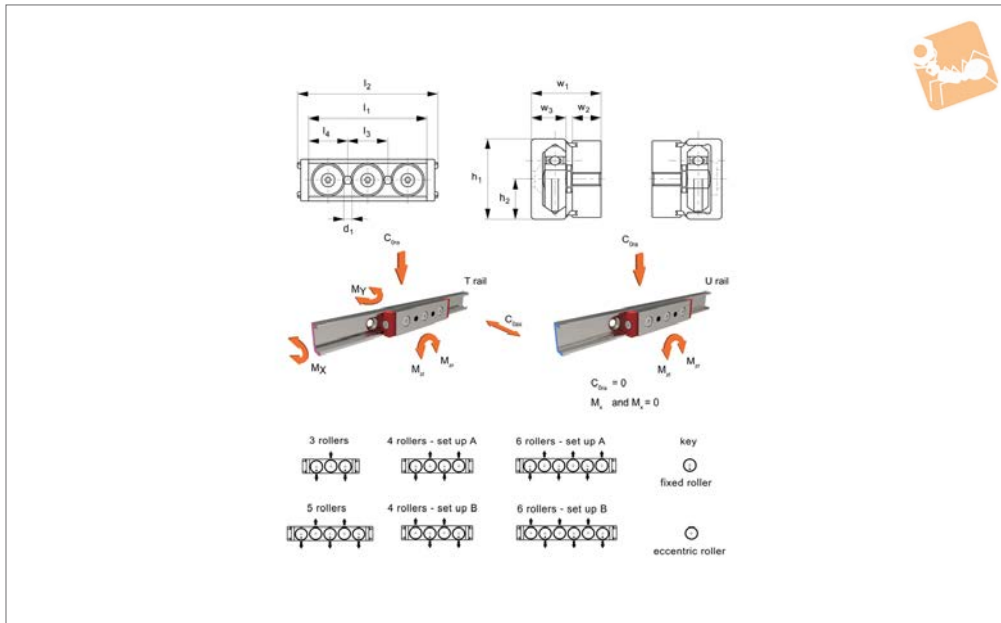

## L1935.CL

LONG LINEAR RAILS

### Material

Zinc plated steel body.  
Steel rollers (100Cr6) with rubber seals.

Select the relevant carriage for the rail and the required number of carriages to carry the load (taking into account any moment loads).

either way up in the rail dependent on where the loads will be applied.  
Easy to install (one or more rollers are eccentric allowing for adjustable preload).  
Coefficient of friction (without seals) 0.003.  
Quiet and fast (up to 5 m/s).

### Technical Notes

To be used with compact rail size 35.

### Tips

The U rail sliders cannot accept axial loads.  
The 3 and 5 bearing sliders can be used

Order No.	For rail type	No. of rollers	d <sub>1</sub>	h <sub>1</sub>	h <sub>2</sub>	l <sub>1</sub>	l <sub>2</sub>	l <sub>3</sub>	l <sub>4</sub>	M <sub>x</sub> Nm	M <sub>y</sub> Nm
L1935.35CL-100-T	T	3	M6	35	17.5	100	114	45	27.5	13.1	34.3
L1935.35CL-100-U	U	3	M6	35	17.5	100	114	45	27.5	0	0
L1935.35CL-120-TA	T	4	M6	35	17.5	120	134	60	30.0	24.3	44.1
L1935.35CL-120-UA	U	4	M6	35	17.5	120	134	60	30.0	0	0
L1935.35CL-120-TB	T	4	M6	35	17.5	120	134	60	30.0	24.3	44.1
L1935.35CL-120-UB	U	4	M6	35	17.5	120	134	60	30.0	0	0
L1935.35CL-150-T	T	5	M6	35	17.5	150	164	30	30.0	24.3	58.8
L1935.35CL-150-U	U	5	M6	35	17.5	150	164	30	30.0	0	0
L1935.35CL-180-TA	T	6	M6	35	17.5	180	194	60	30.0	29.0	75.6
L1935.35CL-180-UA	U	6	M6	35	17.5	180	194	60	30.0	0	0
L1935.35CL-180-TB	T	6	M6	35	17.5	180	194	60	30.0	29.0	75.6
L1935.35CL-180-UB	U	6	M6	35	17.5	180	194	60	30.0	0	0

Order No.	M <sub>Zr</sub> Nm	M <sub>Zl</sub> Nm	w <sub>1</sub> ±0.15	w <sub>2</sub>	w <sub>3</sub>	Dyn. load C N max.	Static load C <sub>0 ax.</sub> N max.	Static load C <sub>0 rad.</sub> N max.
L1935.35CL-100-T	62.7	62.75	30	16.5	12	8200	1080	3580
L1935.35CL-100-U	62.7	62.7	30	16.5	12	8200	0	3580
L1935.35CL-120-TA	53.7	161.2	30	16.5	12	8200	1240	3580
L1935.35CL-120-UA	53.7	161.2	30	16.5	12	8200	0	3580
L1935.35CL-120-TB	161.2	53.7	30	16.5	12	8200	1240	3580
L1935.35CL-120-UB	161.2	53.7	30	16.5	12	8200	0	3580
L1935.35CL-150-T	161.2	161.2	30	16.5	12	9756	1490	4260
L1935.35CL-150-U	161.2	161.2	30	16.5	12	9756	0	4260
L1935.35CL-180-TA	161.2	268.6	30	16.5	12	9756	1810	4260



Order No.	$M_{zr}$ Nm	$M_{zl}$ Nm	$w_1$ $\pm 0.15$	$w_2$	$w_3$	Dyn. load C N max.	Static load $C_{0\text{ ax.}}$ N max.	Static load $C_{0\text{ rad.}}$ N max.
<b>L1935.35CL-180-UA</b>	161.2	268.6	30	16.5	12	9756	0	4260
<b>L1935.35CL-180-TB</b>	268.6	161.2	30	16.5	12	9756	1810	4260
<b>L1935.35CL-180-UB</b>	268.6	161.2	30	16.5	12	9756	0	4260

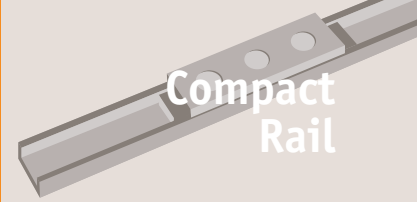

The compact rail systems are unique. They have many major advantages over other rail systems.

### Easy and cost-effective to set up

The rails are easy to set up and can adjust for some misalignment of the structure on which it is being used. The compact rail system achieves this by using a master (T type) rail, and a slave (U type) rail. This allows the sliders in the T rail to remain fixed in place but allows lateral movement of the sliders in the U rail to adapt to any misalignment and avoid any issues of stiction.

Slave (U) rails have flat, parallel raceways that allow free lateral movement of the sliders. This flexibility can mean a large saving in the machining of the structure surface making it a very cost-effective solution.



LONG LINEAR RAILS

### Fast, smooth and quiet

The unique eccentric roller allows easy preload adjustment for smooth running. Very high speeds allowed, very quiet operation.

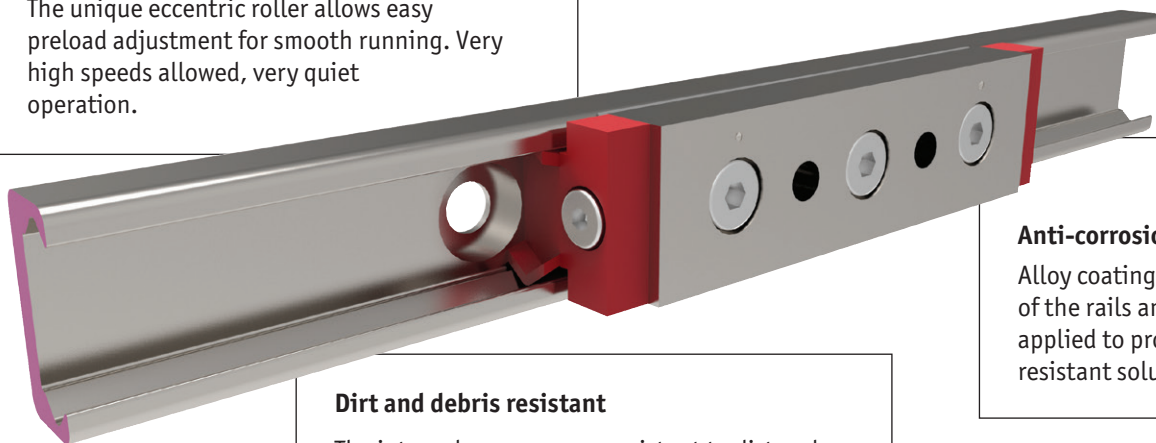

### Anti-corrosion option

Alloy coating or nickel plating of the rails and sliders can be applied to provide a corrosion resistant solution.

### Dirt and debris resistant

The internal raceways are resistant to dirt and debris, larger roller bearings with seals and wipers are used (compared to small ball bearings on other systems).

### Unlimited rail lengths

Rails can be easily joined together for unlimited rail lengths, and extra hole needs to be machined at the joint area. The rails need to be selected so they are "matched" and a joining tool needs to be used to align the rails.

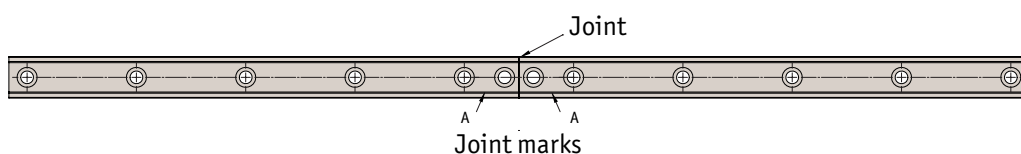



### Specifications

- Maximum speed 9 m/s.
- Maximum acceleration 20 m/s<sup>2</sup>.
- Maximum unjoined rail length 3600 mm.
- 4 rail sizes – 18, 28, 35 and 43.
- Three rail types - T rail, U rail and K rail.
- Rail lengths from 160mm upwards.
- Rail raceways hardened and ground.
- Accuracy 0,15mm over 3,5 metres.
- Maximum radial load per slider is 15,000 N.
- Temperature range -30°C to +120°C.
- Roller bearings seals either 2Z (dust proof) or 2RS (splash proof), lubricated for life.
- Roller bearings from 100Cr6.
- Easy adjustment of preload.
- Three slider body types.
- Rails can be joined together, please contact our Technical Department for details.
- Special anti-corrosion coatings and finishes on request.

### Applications



#### Special purpose & packaging machines

Precision positioning systems  
handling units  
robotic systems • cutting machines



#### Seating

Sliding seats  
disability ramps  
seat extensions



#### Safety guarding

Extending protective systems  
sliding gates  
automatic pick & place



#### Sliding doors & windows

Internal sliding doors  
gates • roof lights  
display cases



#### Photography & lighting

Sliding tracks  
positioning of lights  
shielding systems



#### Medical technology

X-ray equipment  
dental chairs  
bed extensions



#### Food, drink & pharmaceuticals

Food handling conveyors  
pharmaceutical factories  
stainless display equipment



#### Transport (naval)

Sliding hatches  
pull-out storage



#### Transport (rail)

Seat adjustment  
sliding doors  
battery removal units



#### Transport (automotive)

Ambulance sliding systems  
fire fighting vehicles  
sliding panels

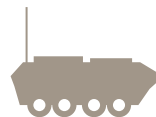

#### Transport (military)

Sliding seats  
protective hatches  
stretcher extensions

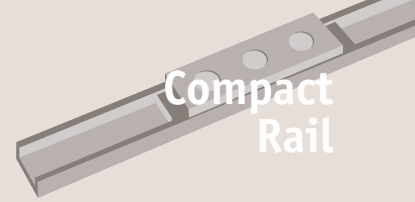

# Compact Rail from Automotion Components

### Rail sizes

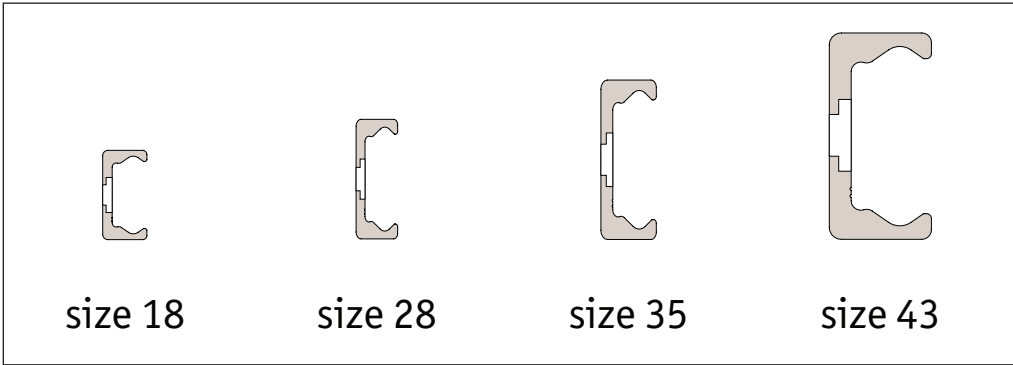

### Rail types

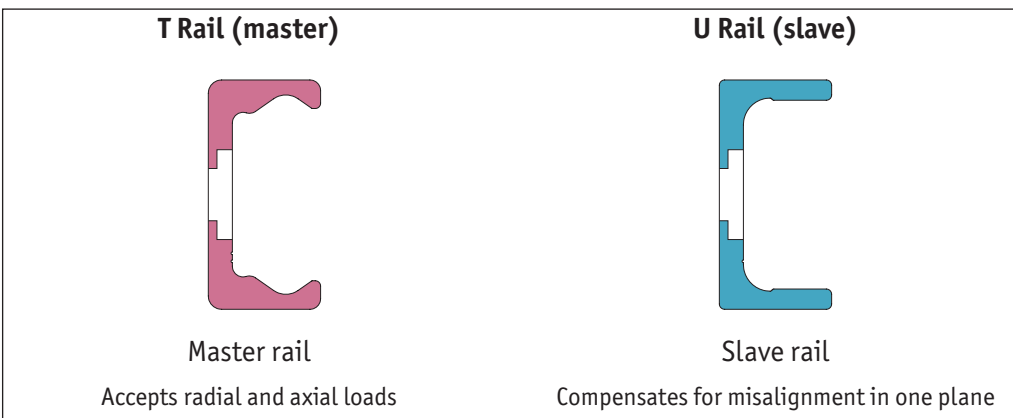

### Sliders

**Solid body, front mount - Type CL**  
Solid steel, zinc plated body  
with removable end wipers  
side seals, fixing in top face



**Solid body, front mount - Type CS**  
Narrow body, solid steel  
zinc plated  
with removable end wipers  
no side seals, fixing on top face



**Solid body, side mount - Type CR**  
Solid steel, zinc plated body  
with removable end wipers  
side seals, fixing in side of body





**Orientation of rails**

The radial load that the sliders can take is significantly higher than the axial load, so where possible the rails should be set up with the sliders taking the loads in this plane.

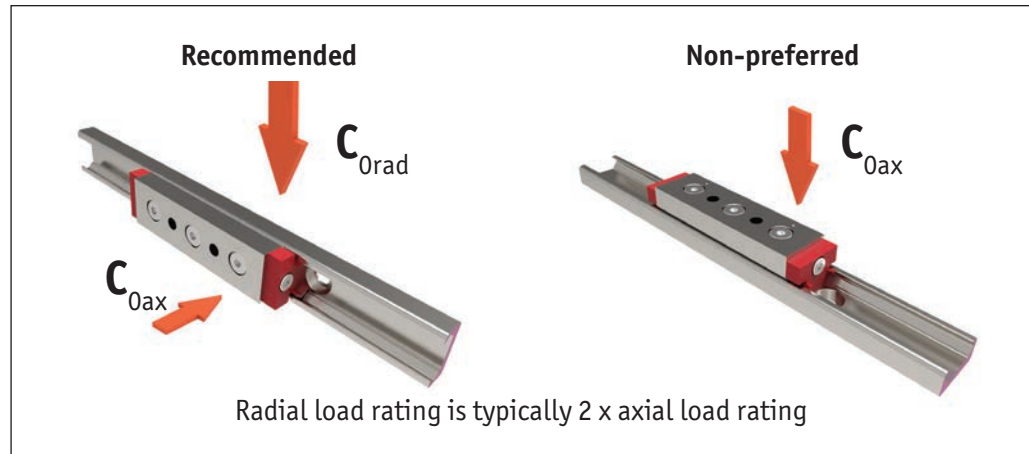

One of the key benefits of the compact rail system is that it compensates for misalignment in the structure. This often results in a major cost saving when compared to the use of other guideways which have to be very accurately installed.

The compact rail system achieves this by using a master (T type) rail, and a slave (U type) rail. This allows the slides in the T rail to remain fixed in place but allows lateral movement of the sliders in the U rail to adapt to any misalignment and avoid any issues of stiction.

U rails have flat, parallel raceways that allow free lateral movement of the sliders. The maximum lateral movement for each size is shown in later tables.

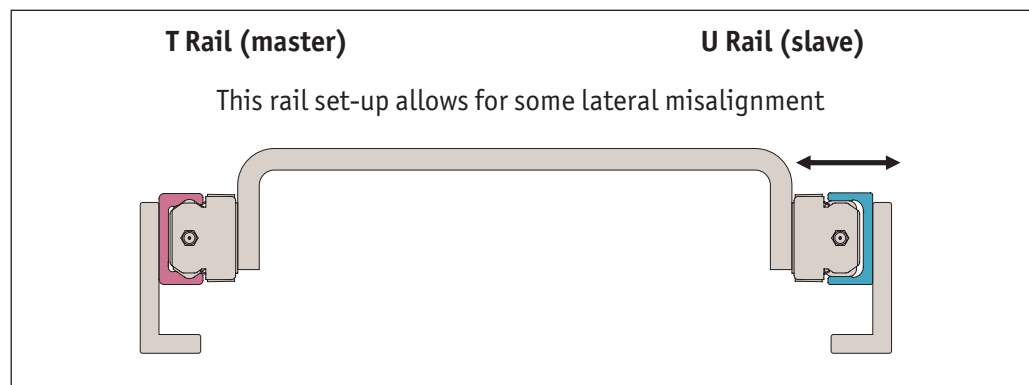

**Using flat rails**

It is acceptable (but not the preferred method), to use rails as below but the alignment accuracy needed is slightly greater and in this set-up only T type rails can be used.

In this case the axial load figure  $C_{0ax}$  should be used in any calculations (which is considerably less than the radial load figure  $C_{0rad}$ ).

