

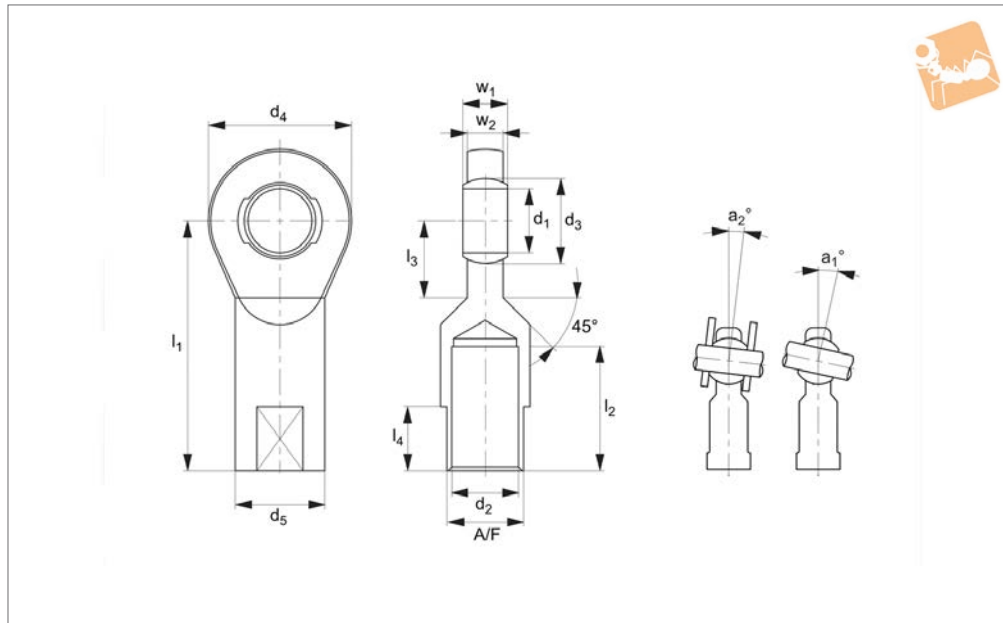

# Heavy-Duty Rod Ends - Female

with integral spherical plain bearing



### R3554

ROD ENDS

#### Material

Rod end housing - forged steel, tempered, surface galvanized.

Joint ball - ball bearing steel, hardened and ground, polished and chromium plated.

Race - nylon/teflon/glass compound.

#### Technical Notes

Female thread maintenance free adapter sizes according to DIN ISO 12240-4, series E.

For tolerances see technical pages.

#### Tips

Standard thread is right hand thread.

#### Important Notes

\*Denotes fine pitch thread.

Order No.	Thread hand	d <sub>1</sub>	l <sub>1</sub>	d <sub>2</sub>	d <sub>3</sub>	d <sub>4</sub>	d <sub>5</sub>	l <sub>2</sub>	l <sub>3</sub>	Weight g
R3554.R006	Right	6	30	M6	10.0	20	10	12	11	17
R3554.R008	Right	8	36	M8	13.0	23	13	16	12	31
R3554.R010	Right	10	43	M10	16.0	28	16	20	13	54
R3554.R011	Right	10	43	M10x1,25*	16.0	28	16	20	13	54
R3554.R012	Right	12	50	M12	18.0	32	19	22	15	86
R3554.R013	Right	12	50	M12x1,25*	18.0	32	19	22	15	86
R3554.R015	Right	15	61	M14	22.0	38	22	25	18	142
R3554.R017	Right	17	67	M16	25.0	44	25	28	20	208
R3554.R020	Right	20	77	M20x1,5*	29.0	51	28	33	23	290
R3554.R025	Right	25	94	M24x2*	35.5	62	35	42	30	573
R3554.R030	Right	30	110	M30x2*	40.7	70	42	51	32	908
R3554.R035	Right	35	125	M36x3*	47.0	82	50	61	38	1230
R3554.R036	Right	35	130	M36x2*	47.0	82	50	66	38	1230
R3554.R040	Right	40	145	M42x3*	53.0	92	58	71	42	2075
R3554.R041	Right	40	142	M39x3*	53.0	92	52	66	42	1880
R3554.R045	Right	45	165	M45x3*	60.0	102	67	76	50	3085
R3554.R046	Right	45	145	M42x3*	60.0	102	58	66	50	2500
R3554.R050	Right	50	195	M52x3*	66.0	112	70	89	60	3975
R3554.R051	Right	50	160	M45x3*	66.0	112	62	69	60	3200
R3554.R060	Right	60	225	M60x4*	80.0	135	82	103	70	7300
R3554.R061	Right	60	175	M52x3*	80.0	135	71	71	70	5900
R3554.L006	Left	6	30	M6	10.0	20	10	12	11	17
R3554.L008	Left	8	36	M8	13.0	23	13	16	12	31
R3554.L010	Left	10	43	M10	16.0	28	16	20	13	54
R3554.L011	Left	10	43	M10x1,25*	16.0	28	16	20	13	54
R3554.L012	Left	12	50	M12	18.0	32	19	22	15	86
R3554.L013	Left	12	50	M12x1,25*	18.0	32	19	22	15	86
R3554.L015	Left	15	61	M14	22.0	38	22	25	18	142
R3554.L017	Left	17	67	M16	25.0	44	25	28	20	208
R3554.L020	Left	20	77	M20x1,5*	29.0	51	28	33	23	290
R3554.L025	Left	25	94	M24x2*	35.5	62	35	42	30	573
R3554.L030	Left	30	110	M30x2*	40.7	70	42	51	32	908



Order No.	Thread hand	d <sub>1</sub>	l <sub>1</sub>	d <sub>2</sub>	d <sub>3</sub>	d <sub>4</sub>	d <sub>5</sub>	l <sub>2</sub>	l <sub>3</sub>	Weight g
R3554.L035	Left	35	125	M36x3*	47.0	82	50	61	38	1230
R3554.L036	Left	35	130	M36x2*	47.0	82	50	66	38	1230
R3554.L040	Left	40	145	M42x3*	53.0	92	58	71	42	2075
R3554.L041	Left	40	142	M39x3*	53.0	92	52	66	42	1880
R3554.L045	Left	45	165	M45x3*	60.0	102	67	76	50	3085
R3554.L046	Left	45	145	M42x3*	60.0	102	58	66	50	2500
R3554.L050	Left	50	195	M52x3*	66.0	112	70	89	60	3975
R3554.L051	Left	50	160	M45x3*	66.0	112	62	69	60	3200
R3554.L060	Left	60	225	M60x4*	80.0	135	82	103	70	7300
R3554.L061	Left	60	175	M52x3*	80.0	135	71	71	70	5900

Order No.	l <sub>4</sub>	w <sub>1</sub>	w <sub>2</sub>	A/F	a <sub>1</sub>	a <sub>2</sub>	Dyn. load C kN max.	Static load C <sub>0</sub> kN max.
R3554.R006	-	6	4	9	13.0	6.5	2.5	10.6
R3554.R008	-	8	5	11	15.0	8.0	4.2	13.1
R3554.R010	-	9	6	14	12.0	6.0	6.4	18.8
R3554.R011	-	9	6	14	12.0	6.0	6.4	18.8
R3554.R012	-	10	7	17	10.5	5.0	9.2	28.0
R3554.R013	-	10	7	17	10.5	5.0	9.2	28.0
R3554.R015	-	12	9	19	8.5	4.5	13.4	41.0
R3554.R017	-	14	10	22	10.0	5.5	19.2	57.9
R3554.R020	-	16	12	24	9.0	4.5	25.2	76.7
R3554.R025	-	20	16	30	7.5	3.5	42.4	119.1
R3554.R030	-	22	18	36	6.0	3.0	54.0	141.8
R3554.R035	36	25	20	41	6.5	3.5	70.4	180.8
R3554.R036	41	25	20	41	6.5	3.5	70.4	180.8
R3554.R040	42	28	22	50	7.0	3.5	86.0	222.6
R3554.R041	39	28	22	46	7.0	3.5	86.0	222.6
R3554.R045	45	32	25	55	7.5	4.0	107.0	276.2
R3554.R046	42	32	25	50	7.5	4.0	107.0	276.2
R3554.R050	52	35	28	60	6.5	3.0	132.0	339.2
R3554.R051	45	35	28	55	6.5	3.0	132.0	339.2
R3554.R060	60	44	36	70	6.5	3.5	208.0	532.1
R3554.R061	52	44	36	60	6.5	3.5	208.0	532.1
R3554.L006	-	6	4	9	13.0	6.5	2.5	10.6
R3554.L008	-	8	5	11	15.0	8.0	4.2	13.1
R3554.L010	-	9	6	14	12.0	6.0	6.4	18.8
R3554.L011	-	9	6	14	12.0	6.0	6.4	18.8
R3554.L012	-	10	7	17	10.5	5.0	9.2	28.0
R3554.L013	-	10	7	17	10.5	5.0	9.2	28.0
R3554.L015	-	12	9	19	8.5	4.5	13.4	41.0
R3554.L017	-	14	10	22	10.0	5.5	19.2	57.9
R3554.L020	-	16	12	24	9.0	4.5	25.2	76.7
R3554.L025	-	20	16	30	7.5	3.5	42.4	119.1
R3554.L030	-	22	18	36	6.0	3.0	54.0	141.8
R3554.L035	36	25	20	41	6.5	3.5	70.4	180.8
R3554.L036	41	25	20	41	6.5	3.5	70.4	180.8
R3554.L040	42	28	22	50	7.0	3.5	86.0	222.6
R3554.L041	39	28	22	46	7.0	3.5	86.0	222.6
R3554.L045	45	32	25	55	7.5	4.0	107.0	276.2
R3554.L046	42	32	25	50	7.5	4.0	107.0	276.2
R3554.L050	52	35	28	60	6.5	3.0	132.0	339.2
R3554.L051	45	35	28	55	6.5	3.0	132.0	339.2
R3554.L060	60	44	36	70	6.5	3.5	208.0	532.1
R3554.L061	52	44	36	60	6.5	3.5	208.0	532.1



## Parts overview



### Heavy Duty Rod Ends: integral spherical plain bearings - series K and series E

Male and female rod ends, maintenance free. These are our most popular range of heavy duty rod ends. Bore diameters 5mm up to 30mm.

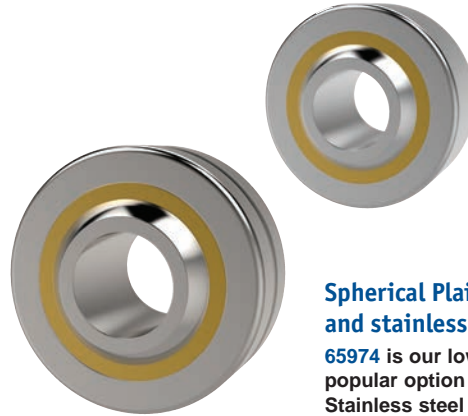

### Spherical Plain Bearings: steel and stainless steel

65974 is our lowest cost, most popular option spherical bearing. Stainless steel version 65976 requires maintenance. 65974 is maintenance free. Bore diameters 5mm up to 30mm.



### Heavy Duty Rod Ends: integral ball bearings - series K and series E

Male and female rod ends. Different bore sizes in relation to the thread size. All require maintenance. Bore diameters 6mm up to 30mm.

### Stainless Steel Heavy Duty Rod Ends: integral spherical plain bearings

Male and female rod ends maintenance free.



### Low Cost Rod Ends: with spherical plain bearing

These are our most popular male and female rod ends. Maintenance free. Female-bore diameters 5mm up to 12mm. Male-bore diameters 5mm up to 16mm.



### Rod Ends with Studs

Steel and Stainless steel, male and female, maintenance free. Sizes M6 up to M16.

see our website for our full range:  
[wixroyd.com](http://wixroyd.com)



All of our rod ends incorporate either a plain spherical bearing, ball bearing, or roller bearing. Below is an overview of each type.

### Plain spherical bearings

- ① Thin coating made from Polyamid-PTFE-fibreglass - compound, maintenance free, absorbs any foreign particles.
- ② Ball made of bearing steel, hardened, ground, polished and hard chromium plated, ensures reliable corrosion protection.
- ③ No clearance - radial clearance 0-10µm.
- ④ All rod end housings made of forged steel, tempered, extremely high load resistances.

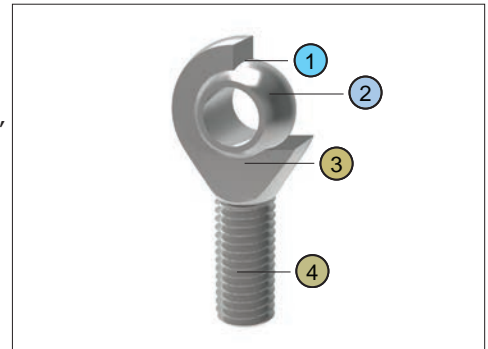

### Ball and roller bearings

- ① Radial clearance: 10-30µm, low friction.
- ② Inner ring made of bearing steel, hardened ball grooves polished.
- ③ Shields on both sides protect against rough dirt penetration.
- ④ All rod ends housings are made of forged steel, case hardened bearing race.
- ⑤ Low maintenance due to long-term greasing, especially suitable for high speed large swiveling angles or rotating movements.

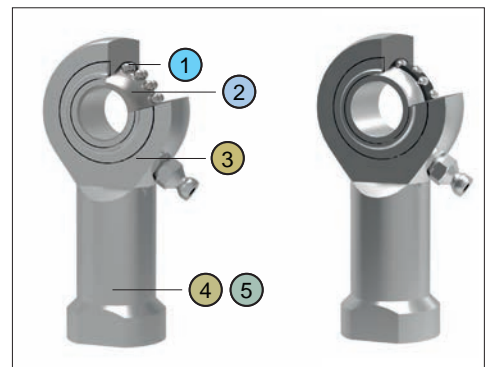

### Rod ends and water

#### Stainless steel versions

Most of our rod ends are available in stainless steel as standard.

High grade AISI 316 stainless steel available on request.







In many cases heavy-duty rod ends with integral spherical plain bearings are most often used. They are above all used for small swivelling or tilting movements at low speeds. They stand out for their high load capacity and can also be used for shock-like loads. The rod end ball slides on a plastic bearing shell consisting of a glass fibre-filled nylon/teflon compound. This design assures a maintenance-free rod end. Heavy-duty plain bearing rod ends have slight initial movement friction and virtually no clearance. The plastic material used has another advantage in that it can absorb many foreign particles so that no damage can occur. The balls of heavy-duty rod ends with integral spherical plain bearings are hard chrome plated. This reliable corrosion protection ensures that the function of the rod end will not be affected by a corroded ball surface under humid operating conditions.

This design is especially suitable for high speeds, large swivelling angles or rotating movements with relatively low or medium loads. Prominent technical features are the low bearing friction, long-time greasing as well as the sealing against some dirt penetration (by means of shields on both sides). Under normal operating conditions the rod ends are maintenance-free. Greasing nipples are provided for lubrication in case of rough operations and maximum loads. To avoid incompatibility with the production lubrication, we recommend lubrication with a calcium-complex-soap-grease. A special heat treatment procedure gives the rod end housing a raceway hardness adapted to the antifriction bearing, ensuring at the same time high stability with changing loads.

This design, based on the structure of a self-aligning roller bearing is preferably used for high speed, large tilting angles or rotating movements under high loads. Compared to rod ends with ball bearings, rod ends with self-aligning roller bearings essentially have higher basic load ratings. This design is equipped with a cage to minimise the rolling friction and heat build-up. These rod ends, with long-time lubrication are under normal operating conditions maintenance-free. Greasing nipples are provided for lubrication in case of rough operations and maximum loads. To avoid incompatibility with the production lubrication, we recommend lubricating with a calcium-complex-soap-grease. Shields on both sides limit dirt particles from penetrating into the bearing. The rod ends with roller bearings are subjected to a special heat treatment to obtain a raceway hardness adapted to the antifriction bearings, ensuring at the same time a high stability with changing loads.

## Rod end bearings load capacity explained

The static load capacity  $C_0$  is the radially acting static load which does not cause any permanent deformation of the components when the spherical bearing or rod end is stationary, (i.e. the load condition without pivoting, swivelling or tilting movements). It is also a precondition here that the operating temperature must be at normal room temperature and the surrounding components must possess sufficient stability.

The values specified in the tables are determined by static tension tests on a representative number of series components at 20°C normal room temperature. The static load capacity may vary with lower or higher temperature depending on the material. In the case of all rod ends with plain bearings, the static load rating refers to the maximum permissible static load of the rod end housing in a tensile direction up to which no permanent deformation occurs at the weakest housing cross-section. The value in the product tables has a safety factor of 1.2 times the tensile strength of the rod ends housing material.

For our rod ends with roller and ball bearings, the static load rating is the load at which the bearing can operate at room temperature without its performance being impaired as a result of deformations, fracture, or damage to the sliding contact surfaces (max 1/10,000<sup>th</sup> of the ball diameter).

Dynamic load ratings serve as values for calculation of the service life of dynamically-loaded spherical bearings and rod ends. The values themselves do not provide any information about the effective dynamic load capacity of the spherical bearing or rod end. To obtain this information, it is necessary to take into account the additional influencing factors such as load type, swivel or tilt angle, speed characteristic, max. permitted bearing clearance, max. permitted bearing friction, lubrication conditions and temperature, etc.

Dynamic load capacities depend on the definition used to calculate them. Comparison of values is not always possible owing to the different definitions used by various manufacturers, and because the load capacities are often determined under completely different test conditions.

For our rod ends with roller and ball bearings, the dynamic load capacity is the load at which 90% of a large quantity of identical rod ends reach 1 million revolutions before they fail (due to fatigue of the rolling surfaces.)

## Rod ends with integral maintenance-free spherical plain bearings

## Rod ends with integral ball bearings

## Rod ends with integral roller bearings

## Static load capacity $C_0$ (plain bearings)

## Static load capacity $C_0$ (roller and ball bearings)

## Dynamic load capacity C (plain bearings)

## Dynamic load capacity C (roller and ball bearings)



**Operating temperatures**

Heavy-duty ball and roller bearing rod ends can be used for operating temperatures between -20°C and +120°C. The temperature range of heavy-duty rod ends with integral spherical plain bearing is between -30°C and +60°C, without affecting the load capacity. Higher temperatures will reduce the load capacity taken into account for the calculation of the 'working life' under the temperature factor  $C_2$  on page 451.

**Loads**

The decisive parameters for the selection and calculation of heavy-duty rod ends are size, direction and type of load.

**Radial or combined loads**

The heavy-duty rod ends have been especially designed to cope with high radial loads. They can be used for combined loads, the axial load share of which does not exceed 20% of the corresponding radial load.

**Unilaterally acting load**

In this case the load acts only in the same direction, which means that the load area is always in the same bearing section.

**Alternately acting load**

In case of alternating loads, the load areas facing each other are alternately loaded and/or relieved, which means that the load changes its direction constantly by approximately 180°.

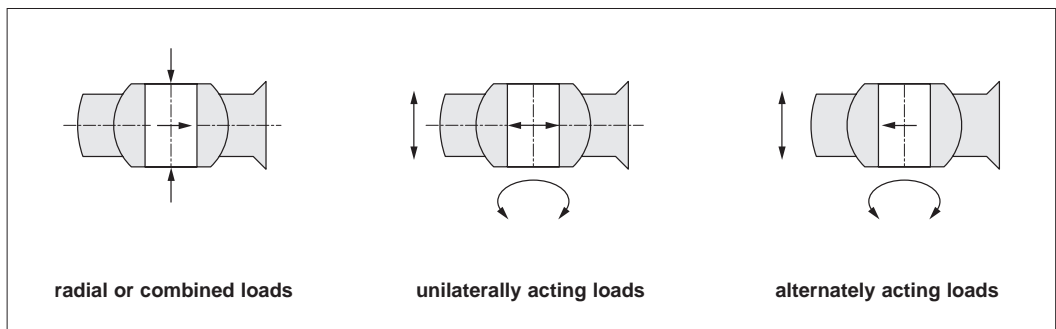

**Swivelling angle**

The swivelling angle is the movement of the rod end from one final position to the other. Half the swivelling angle  $a^\circ$  is used to calculate the service or 'working life'.

